

WAYNE®

Shallow Well Jet Pump Water Systems

Please read and save these instructions. Read carefully before attempting to assemble, install, operate or maintain the product described. Protect yourself and others by observing all safety information. Failure to comply with instructions could result in personal injury and/or property damage! Retain instructions for future reference.

Operating Instructions and Parts Manual

SWS

SPECIFICATIONS	
POWER SUPPLY REQUIREMENTS	120 or 230 V, 60 Hz
MOTOR	Single Phase AC Induction
HORSEPOWER	1/2 HP.....(SWS50) 3/4 HP.....(SWS75) 1 HP(SWS100)
CUT IN PRESSURE	30 PSI
CUT OUT PRESSURE	50 PSI

CONSTRUCTION	
MOTOR HOUSE	Carbon Steel
SEAL PLATE	Cast Iron
DIFFUSER	Thermoplastic
IMPELLER	Thermoplastic
SHAFT	Stainless Steel
PUMP SUCTION	1-1/4 in. NPT
PUMP DISCHARGE	1 in. NPT

PERFORMANCE								
Model	HP	PSI	Discharge Head (Lift Distance)					
			0 ft	5 ft	10 ft	15 ft	20 ft	25 ft
SWS50	1/2	30	711	674	638	601	565	529
		40	543	506	470	433	397	361
		50	375	338	302	265	229	193
SWS75	3/4	30	779	750	721	691	662	633
		40	644	615	586	557	528	499
		50	510	481	451	422	393	364
SWS100	1	30	1084	1022	960	899	837	775
		40	799	737	675	613	551	490
		50	513	451	389	328	266	204

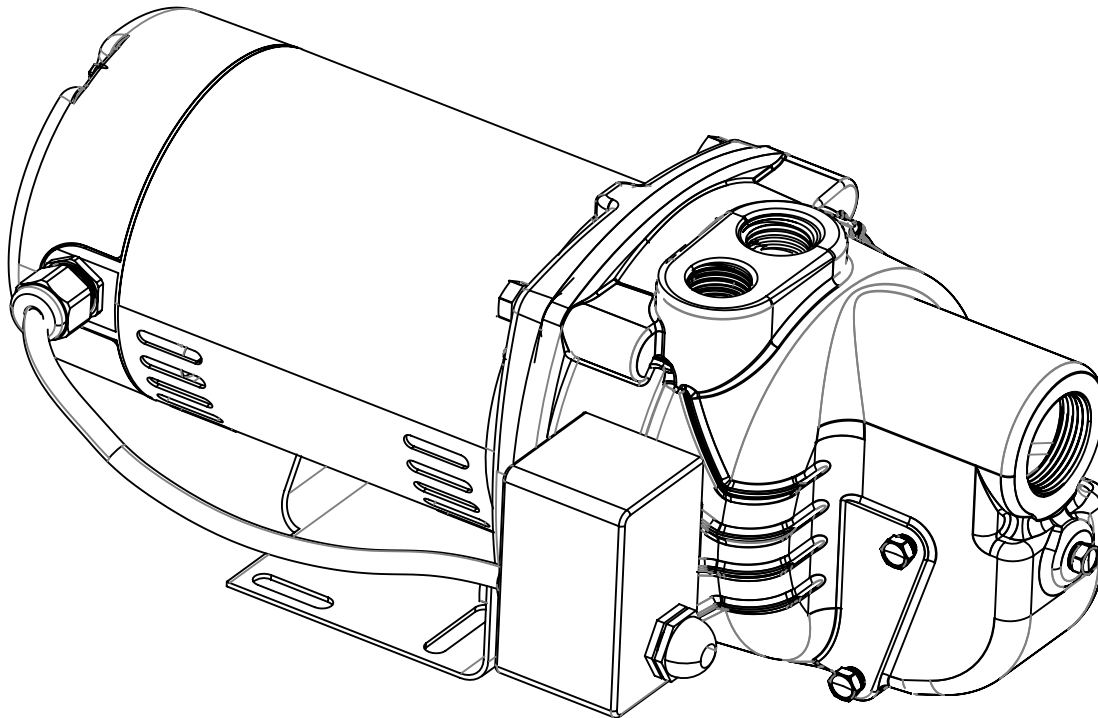

Intended for Indoor Use Only

Operating Instructions and Parts Manual

DESCRIPTION

Shallow well jet pumps are single stage residential water pumps designed for pumping potable water in applications where the water is located less than 25 feet vertically from the pump. A pressure switch is a standard feature. The shallow well pump must be mounted to either a pre-charged, conventional type or free standing pressure tank.

Intended for indoor use only. Installation of this pump outdoors, unprotected from the weather, may cause hazardous conditions and will void warranty. If using outdoors, protect pump from direct weather elements such as sun, rain, sleet, snow, and extreme temperature changes. Water inside the pump may freeze, limiting its performance and damaging the pump and pipes.

UNPACKING

Inspect this unit before it is used. Occasionally, products are damaged during shipment. If the pump or components are damaged, return the unit to the place of purchase for replacement, or call Customer Support (800-237-0987).

SAFETY SIGNAL WORDS

This manual contains information that is very important to know and understand. This information is provided for SAFETY and to PREVENT EQUIPMENT PROBLEMS. To help recognize this information, observe the following symbols.

⚠ DANGER Danger indicates an imminently hazardous situation which, if NOT avoided, WILL result in death or serious injury.

⚠ DANGER La mention Danger indique une situation dangereuse imminente qui, si elle n'est pas évitée, ENTRAÎNE la mort ou des blessures graves.

⚠ WARNING Warning indicates a potentially hazardous situation which, if NOT avoided, COULD result in death or serious injury.

⚠ AVERTISSEMENT La mention avertissement indique une situation potentiellement dangereuse qui, si elle n'est pas évitée, risque d'entraîner des lésions corporelles graves ou même la mort.

⚠ CAUTION Caution indicates a potentially hazardous situation which, if NOT avoided, MAY result in minor or moderate injury.

⚠ MISE EN GARDE La mention mise en garde indique une situation potentiellement dangereuse qui, si elle n'est pas évitée, pourrait entraîner des blessures mineures ou modérées.

GENERAL SAFETY INFORMATION

CALIFORNIA PROPOSITION 65

⚠ WARNING

This product can expose you to chemicals, including DEHP, which is known to the State of California to cause cancer, birth defects and reproductive harm. For more information, go to www.P65Warnings.ca.gov

⚠ AVERTISSEMENT

Ce produit peut vous exposer à des produits chimiques, notamment du DOP, reconnus par l'État de Californie comme étant cancérigènes et à l'origine d'anomalies congénitales et de problèmes de l'appareil reproductif. Pour plus de renseignements, visiter le site www.P65Warnings.ca.gov

GENERAL SAFETY

1. Read the instruction manual included with the product carefully. Be thoroughly familiar with the controls and the proper use of the equipment.
2. Know the pump application, limitations and potential hazards.

⚠ WARNING ALWAYS install a pressure relief valve to match the system pressure rating and the maximum flow rate when required by local codes.

⚠ AVERTISSEMENT TOUJOURS installer une soupape de surpression correspondant à la pression nominale et au débit maximal du système lorsque requis par les codes locaux.

⚠ DANGER Do NOT use to pump flammable or explosive fluids such as gasoline, fuel oil, kerosene, etc. Do NOT use in explosive atmospheres. Pump only clear water. Failure to follow this warning WILL result in personal injury and/or property damage, and will void warranty.

⚠ DANGER NE PAS utiliser pour pomper des fluides inflammables ou explosifs tels que l'essence, le mazout, le kérosène, etc. NE PAS utiliser dans des atmosphères explosives. Pomper uniquement de l'eau claire. Le non-respect de cet avertissement entraînera des blessures corporelles et/ou des dégâts matériels et annulera la garantie.

REMINDER: Keep your dated proof of purchase for warranty purposes! Attach it to this manual or file it for safekeeping.

GENERAL SAFETY INFORMATION (CONT'D)

▲ WARNING *Disconnect power and release all pressure from the system before attempting to install, service, relocate or perform any maintenance. Lock the power disconnect in the open (OFF) position. Tag out the power disconnect to prevent unexpected application of power.*

▲ AVERTISSEMENT *Débrancher de la source d'alimentation puis dissiper toute la pression du système avant d'essayer d'installer, de réparer, de déplacer ou de procéder à l'entretien. Verrouiller le sectionneur de courant en position ouverte (OFF). Étiqueter le sectionneur de courant pour éviter toute mise sous tension imprévue.*

3. Drain all liquids from the system before servicing.
4. Periodically inspect pump and system components. Perform routine maintenance as required (See Maintenance on page 7).

Personal Safety:

- a. Wear safety glasses at all times when working with pumps.
- b. Keep work area clean, uncluttered and properly lighted - replace all unused tools and equipment.
- c. Keep visitors at a safe distance from work area.
- d. Make the workshop childproof use padlocks, master switches and remove starter keys.
5. Do NOT pump chemicals or corrosive liquids. Pumping these liquids shortens the life of the seals and moving parts, this WILL void the warranty. Pump only clear water.
6. When installing pump, cover the well to prevent foreign matter from falling into well contaminating the water, and damaging internal mechanical pumping components.
7. Always test the water from the well for purity before use. Check with local health department for test procedure.
8. Complete pump and piping system MUST be protected against freezing temperature. Freezing temperatures could cause severe damage and void the warranty.
9. Do not run the pump dry or damage will occur and will void warranty.

▲ WARNING *Risk of electrical shock! This pump is designed for indoor installation only.*

▲ AVERTISSEMENT *Risque de choc électrique! Cette pompe est conçue seulement pour une utilisation à l'intérieur.*

▲ WARNING *Risk of Electrical Shock! All wiring SHOULD be performed by a licensed or certified electrician.*

▲ AVERTISSEMENT *Risque de choc électrique! Tout le câblage DOIT être effectué par un électricien qualifié ou certifié.*

10. Pressure switch is factory set at 30 ON/ 50 OFF and is NOT to be changed (will void warranty).
11. Before installing the pump, have the electrical circuit checked by a licensed or certified electrician to make sure the circuit is properly grounded.
12. The circuit voltage and frequency of electrical current must correspond with the specifications of the motor.
13. Do NOT attempt repairs to the electric motor. All repairs to the motor must be completed by a licensed electrician.

▲ WARNING *Do NOT touch an operating motor. Modern motors are designed to operate at high temperatures.*

▲ AVERTISSEMENT *Ne touchez PAS un moteur en fonctionnement. Les moteurs modernes sont conçus pour fonctionner à des températures élevées..*

14. Avoid kinking electrical wire and protect from sharp objects, hot surfaces, oil and chemicals.
15. Keep fingers and foreign objects away from ventilation and other openings. Do NOT insert any objects into the motor.

▲ WARNING *Risk of electric shock! NEVER connect the green (or green/yellow) wire to a live terminal!*

▲ AVERTISSEMENT *Risque de choc électrique! Ne JAMAIS brancher le fil vert (ou vert et jaune) à une borne sous tension!*

16. To reduce the risk of electrical shock. The motor must be securely and adequately grounded for protection against shock.
17. Use wire of adequate size to minimize voltage drop at the motor per local code. See Chart 3 on Page 6.

▲ WARNING *Do NOT handle pump or pump motor with wet hands, when standing on a wet or damp surface or when standing in water. Fatal electrical shock COULD occur.*

▲ AVERTISSEMENT *NE PAS manipuler de pompe ou de moteur de pompe avec les mains humides ou debout dans l'eau ou sur une surface humide. Ceci POURRAIT occasionner un choc électrique mortel.*

▲ CAUTION *Pump motor is equipped with an automatic resetting thermal protector and MAY restart unexpectedly. Protector tripping is an indication of motor overheating because of operating pump at low heads (low discharge restriction), excessively high or low voltage, inadequate wiring, incorrect motor connections, excessive surrounding air temperature, inadequate ventilation, and/or defective motor or pump.*

▲ MISE EN GARDE *Le moteur de la pompe est doté d'un protecteur thermique à réinitialisation automatique et POURRAIT redémarrer de manière imprévue. Le déclenchement du protecteur est une indication de surchauffe du moteur à cause d'une utilisation de la pompe à faible hauteur de chute (restriction de faible décharge), d'une tension excessivement haute ou basse, d'un câblage inadéquat, d'un branchement incorrect du moteur, d'une température ambiante excessive, d'une ventilation inadéquate ou d'une pompe ou d'un moteur défectueux.*

PRE-INSTALLATION

WATER STORAGE

Tanks are required for these pumps to operate as designed.

Operating Instructions and Parts Manual

PRE-INSTALLATION (CONT'D)

TANKS - CONVENTIONAL STORAGE

The function of the tank is to store a quantity of water under pressure. When full, the tank contains approximately 2/3 water and 1/3 compressed air. Then compressed air forces the water out of the tank when a faucet is opened. An air volume control automatically replaces air lost or absorbed into the water. The usable water, or drawdown capacity, of the tank is approximately 1/6 of the tanks total volume when operated on a 30/50 pressure setting (Figure 1).

TANKS - PRECHARGED STORAGE

A precharged storage tank has a flexible bladder or diaphragm that acts as a barrier between the compressed air and water. This barrier prevents the air from being absorbed into the water and allows the water to be acted on by compressed air at initially higher than atmospheric pressures (precharged). More usable water is provided than with a conventional type tank. Precharged tanks are specified in terms of a conventional tank. For example, a 20 gallon precharged tank will have the same usable water or drawdown capacity as a 40 gallon conventional tank, but the tank is smaller in size (Figure 1).

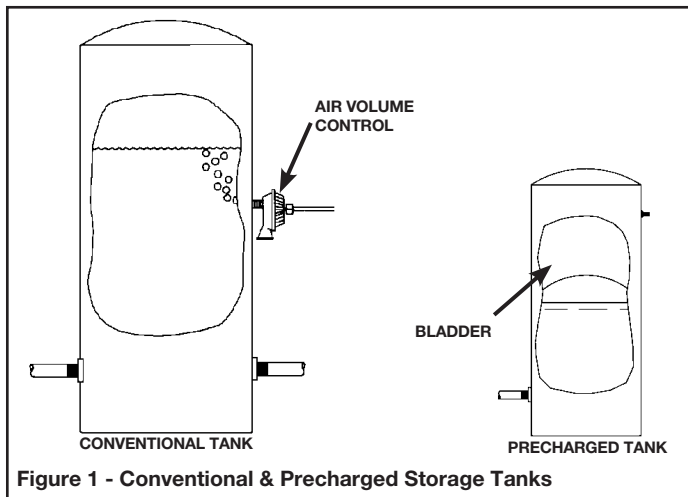

Figure 1 - Conventional & Precharged Storage Tanks

INSTALLATION

LOCATION

Select a location as close to the water supply as possible. Be sure to comply with any state or local codes regarding the placement of the pump. The equipment must be protected from the elements or voids warranty. A basement or heated pump house is a good location. Make sure the pump has proper ventilation. The temperature surrounding the pump is not to exceed 100° F (38°C) or nuisance tripping of the motor overload may occur.

WELLS

A new well should be pumped clear of sand before installing the pump. Sand will damage the pumping parts and seal. The draw-down level of the well should not exceed the maximum rated depth for the pump. The capacity of the pump will be reduced and a loss of prime may occur.

PIPING

Inlet piping may be copper, steel, or rigid PVC plastic.

CAUTION Flexible pipe is prohibited on suction pipe (inlet pipe).

MISE EN GARDE Un tuyau flexible est interdit sur le tuyau d'aspiration (tuyau d'entrée).

The pipe must be clean and free of rust or scale. Use a pipe joint compound on the male threads of the metal pipe. Plumber's seal tape should be used with plastic threads. All connections must be air tight to insure normal operation.

Slope all inlet piping upwards towards the pump to prevent trapping air. Unions or hose couplings can be installed near pump to facilitate removal for servicing or storage. A rubber hose installed between the water system and the house piping will reduce the noise transmitted to the house.

PRESSURE SWITCH

The pressure switch provides for automatic operation. The pump starts when pressure drops to a cut-in setting. The pump stops when pressure reaches a cut-out setting. The pressure switch is preset and is **NOT** adjustable.

PIPE SIZES

Long horizontal pipe runs and an abundance of fittings and couplers decrease water pressure due to friction loss. See Chart 2 below to determine the proper pipe size.

CHART 2 - PIPE SIZING

Pump Model	Pump Opening	0-25	26-100	100-300
Shallow Well	Inlet	1-1/4 in.	1-1/2 in.	2 in.

SHALLOW WELL INSTALLATION

A shallow well pump can be used when the pump is located less than 25 feet vertically of the water level. Shallow well pumps have only one pipe between the pump and the water supply (Figure 2).

DRILLED WELL (FIGURE 12 ON PAGE 11)

1. Install a foot valve on the first section of pipe (Figure 2, Illustration A).
2. Lower the pipe into the well.
3. Add pipe until the foot valve is 5 feet below the lowest anticipated water level.

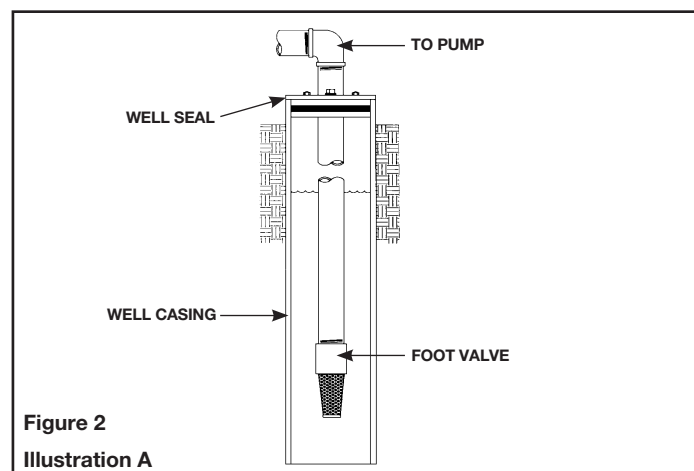

Figure 2
Illustration A

Operating Instructions and Parts Manual

▲ CAUTION The foot valve **MUST** be at least 18" from the bottom of the well or sand or sediment **WILL** be drawn into the system.

▲ MISE EN GARDE Le clapet de pied **DOIT** au moins être à 45,7 cm (18 po) du fond du puits, sinon du sable ou des sédiments **POURRAIENT** être aspirés dans le système

- After proper depth is reached, install a well seal or pitless adapter to support pipe and prevent surface water and other contaminants from entering well.

INSTALLATION (CONT'D)

- Slope the horizontal pipe upward toward the pump to eliminate trapping air. Sloping the pipe will also aid in priming the pump.

DRIVEN WELL (FIGURE 12 ON PAGE 11)

- Drive the point several feet below the water table.

NOTE: A packer type foot valve can be installed in the well (Figure 2, Illustration B). This type of foot valve allows the well to be filled with water when priming and makes the inlet pipe much easier to test for leaks. Follow the manufacturer's instructions when installing the packer type foot valve.

As an alternative, an in-line check valve can be used with a driven well (Figure 2, Illustration C). The pipe between the check valve and the water level will always be under a vacuum.

Leaking joints or couplings will allow air to leak into the pipe and cause abnormal pump operation. Make sure to use pipe joint compound on all male pipe threads.

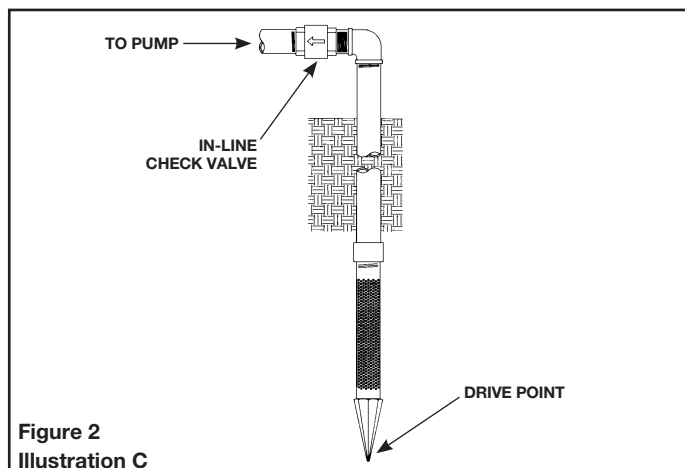
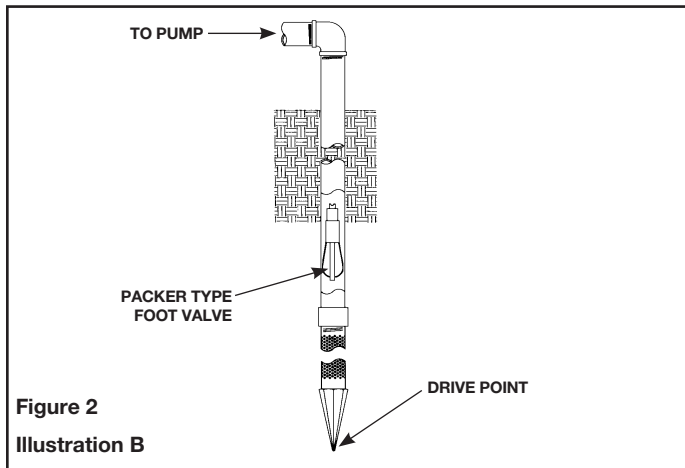

DUG WELL, CISTERN, LAKE AND SPRING INSTALLATION (FIGURE 12 ON PAGE 11)

- Install a foot valve on inlet pipe and lower into water.

▲ CAUTION The foot valve **MUST** be at least 18" from the bottom of the well or sand or sediment **WILL** be drawn into the system.

▲ MISE EN GARDE Le clapet de pied **DOIT** au moins être à 45,7 cm (18 po) du fond du puits, sinon du sable ou des sédiments **POURRAIENT** être aspirés dans le système

NOTE: When a lake is used as a water supply, make sure the inlet pipe is deep enough to be submerged at all times. Slope the horizontal piping upward toward the pump to prevent trapping air. The pipe must be removed during winter months or protected against freezing. Protect the pipe from damage from swimmers and boats.

▲ CAUTION Install a screen around the inlet pipe to prevent the entrapment of swimmers, wildlife and debris.

▲ MISE EN GARDE Installer un écran autour du tuyau d'entrée pour éviter de piéger des nageurs, des animaux et des débris.

SHALLOW WELL PUMP WITH CONVENTIONAL STORAGE TANK

- Install air volume control on tank.
- Connect the copper tube from the air volume control to the uppermost 1/8" NPT opening on the side of pump. Be sure the connections are tight. Leaking can cause the pump not to prime (Figure 3).

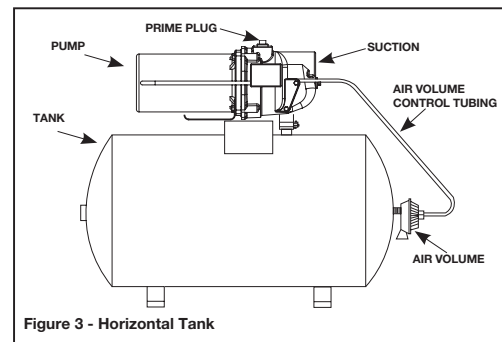

- Install a valve and an isolator hose between the tank and the house plumbing to aid in pump removal for servicing and for reducing the noise transmitted to the house through the piping.
- Provide a faucet at the lowest point in the system to drain the system for service or storage.

SHALLOW WELL PUMP WITH PRECHARGED STORAGE TANK

- Shut off the power to the pump.
- Open the faucet nearest the tank and allow all water to drain from the tank.
- Measure the tank precharge at the valve stem using a tire pressure gauge.
- If necessary, precharge with an air pump to 28 - 30 psi on 1/2HP and 3/4HP pumps.
- Slope the horizontal pipes upward toward the pump to prevent trapping air. If the horizontal distance exceeds 25 feet, see Chart 2 on page 4 for the recommended pipe size.

Operating Instructions and Parts Manual

ELECTRICAL

▲ WARNING Risk of electrical shock. This pump is designed for indoor installation unless housed and protected from the elements.

▲ AVERTISSEMENT Risque de choc électrique! Cette pompe est conçue pour une utilisation à l'intérieur, sauf si elle est à l'abri et protégée contre les intempéries.

- This installation must be in accordance with the National Electric Code and all applicable local codes and ordinances.
- The voltage of power supply must match the voltage of the pump. The motors can be converted to 115 or 230 volts by changing the voltage selector to the desired voltage. Remove rear cover of motor by unscrewing both screws to expose voltage selector. Rotate dial so desired voltage is completely visible within notch (Figure 4).

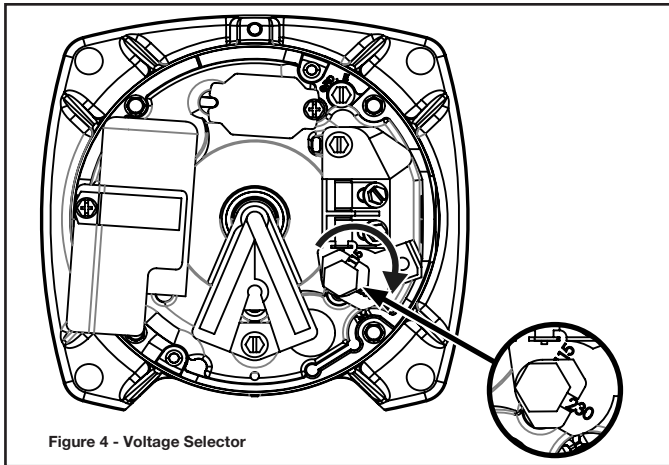

- If wire run is a short distance, a cord/plug assembly may be used as long as it meets the minimum wire gage size, called out in Chart 3, above. Time delay fuses are recommended over standard fuses for motor circuit protection. All pump motors have built-in automatic overload protection that will prevent damage to the motor due to overheating.
- Do NOT connect to electric power supply until unit is permanently grounded. Connect ground wire to approved ground then connect terminal provided.
- A metal underground water pipe or well casing at least 10 feet long makes the best ground electrode. If plastic pipe or insulated fittings are used, run a wire directly to the metal well casing or use a ground electrode furnished by the power company.
- There is only one proper ground terminal on the unit. The terminal(s) is located under the pressure switch cover, is painted green and is identified as GRD. The ground connection must be made at this terminal (Figure 5). The ground conductor must not be smaller than the circuit conductors supplying the motor.

▲ WARNING Disconnect power and release all pressure from the system before attempting to install, service, relocate or perform any maintenance.

▲ AVERTISSEMENT Débrancher de la source d'alimentation puis dissiper toute la pression du système avant d'essayer d'installer, de réparer, de déplacer ou de procéder à l'entretien.

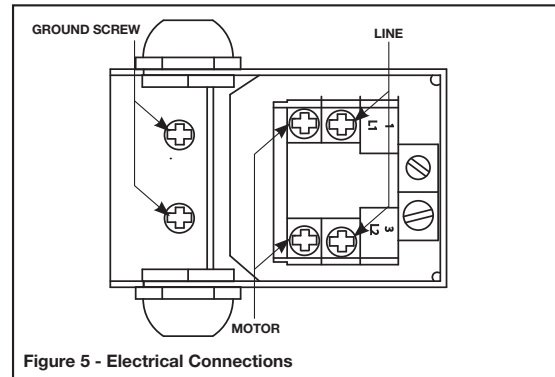

OPERATION

PRIMING THE SHALLOW WELL PUMP

▲ WARNING To prevent damage to the pump, do NOT start motor until pump has been filled with water.

▲ AVERTISSEMENT Pour éviter d'endommager la pompe, ne pas démarrer le moteur tant que la pompe n'a pas été remplie d'eau.

1. Remove prime plug (Figure 3).
 2. Fill pump and piping completely full of water.
 3. Replace the prime plug.
 4. Open a faucet to vent the system.
 5. Start the motor. Water will pump in a few minutes. If pump fails to prime in 5 minutes, stop motor and refill pump with water. Priming time is proportional to the amount of air in inlet pipe.
 6. Let the system operate for several minutes to flush all pipes.
 7. Close faucet and allow pump to build pressure in tank. When the pressure reaches the cut-out setting, the motor will stop.
- The system is now in operation and will automatically cycle on demand.

Operating Instructions and Parts Manual

MAINTENANCE

▲ WARNING *Disconnect power and release all pressure from the system before attempting to install, service, relocate or perform any maintenance. Lock the power disconnect in the open (OFF) position. Tag out the power disconnect to prevent unexpected application of power.*

▲ AVERTISSEMENT *Débrancher de la source d'alimentation puis dissiper toute la pression du système avant d'essayer d'installer, de réparer, de déplacer ou de procéder à l'entretien. Verrouiller le sectionneur de courant en position ouverte (OFF). Étiqueter le sectionneur de courant pour éviter toute mise sous tension imprévue.*

▲ CAUTION *Protect the pump from freezing during winter conditions.*

▲ MISE EN GARDE *Protéger la pompe du gel pendant l'hiver.*

DRAINING THE PUMP

Drain openings are provided on all models.

To drain the pump:

1. Remove drain fitting and prime plug to vent the system (see Figure 7).
2. Drain all piping to a point below the freeze line.

DRAINING THE TANK

Conventional tanks can be drained by opening an outlet at the lowest point in the system. Remove plug or the air volume control to vent the tank.

Precharged tanks force virtually all the water from the tank when system pressure is released. No draining is necessary.

RESTARTING PUMP

If the pump has been serviced, drained or has not been used for some time, be sure there is water in the pump housing (volute) and the piping to the well. There must be water in the pump housing (volute) at all times when the pump is running to avoid internal damage of seal members.

WATERLOGGED TANKS: CONVENTIONAL

When a tank system has an inadequate ratio of air and water, the pump will start and stop often and erratically.

1. Disconnect the power to the pump.
2. Open the lowest faucet in the system to release all pressurized water in the system.
3. Prime the pump (Priming the Shallow Well Pump on page 6).
4. Reconnect the power to the pump.

NOTE: As the pump refills the tank with water, the air volume control supplies the tank with the correct air to water ratio for the system to operate. If the air volume control is good, the pump will shut off at the desired cut-off and will be adjusted correctly.

WATERLOGGED TANKS: PRECHARGED

If a precharged tank becomes waterlogged, the bladder is normally leaking or broken.

1. Test the tank by depressing the air valve. The air valve will expel water if the bladder is broken.
2. If broken, replace the tank.

NOTE: Once a bladder is leaking or broken, the bladder cannot be repaired. The tank must be replaced.

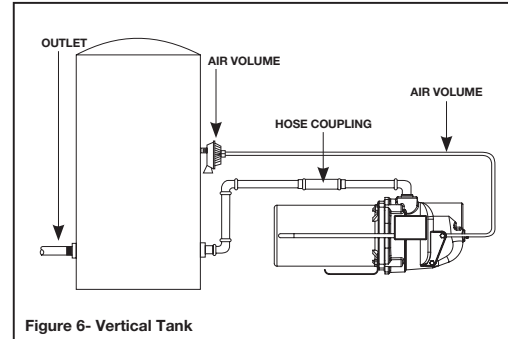

Figure 6 - Vertical Tank

LUBRICATION

The bearings used in the pumps are lifetime lubricated at the factory and require no additional lubrication.

PRECHARGED TANK

Some air is lost through the bladder in any tank. To prevent tank failure, check the tank precharge on a yearly basis.

1. Disconnect power to the pump, so water does not refill the precharged tank.
2. Open a faucet nearest to the tank and allow all water to drain from the tank, then close.
3. Measure the tank precharge at the valve stem using a tire gauge.
4. If necessary, adjust the precharge with an air pump 28 - 30 psi on the pump.
5. Reconnect power to the pump.

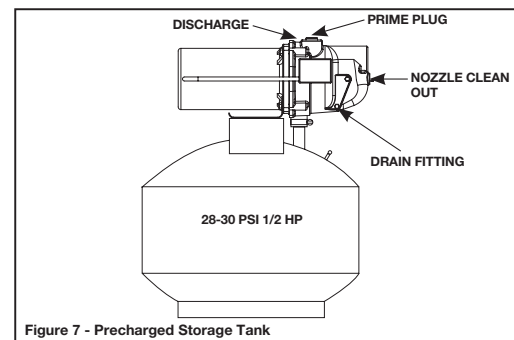

Figure 7 - Precharged Storage Tank

KITS SECTION

REMOVING OLD SHAFT SEAL *Disconnect power and release all pressure from the system before attempting to install, service, relocate or perform any maintenance.*

1. Disconnect power to the pump.
2. Open a faucet nearest to the tank and allow all water to drain from the tank, then close.
3. Remove the four cap screws holding the pump housing (volute) to the motor (Figure 8).
4. Separate the pump housing (volute) from the motor to expose the diffuser and the seal plate.
5. Remove the two cap screws and diffuser from the seal plate to expose the impeller.
6. Remove the rear cover on the end of the motor opposite the impeller.
7. Secure a 7/16" wrench across wrench flats of shaft to keep the shaft from rotating and remove the impeller by hand (standard right hand thread). Be sure to hold onto the seal plate when removing the impeller from the shaft.

Operating Instructions and Parts Manual

KITS SECTION (CONT'D)

8. Remove the seal plate.
9. Pry the rotating shaft seal member (including stainless collar and rubber seal) from the impeller (Figure 9).
10. Push or pry the ceramic seat, and rubber seat ring free from the seal plate (Figure 9).
11. Remove loose particles from impeller hub and seal plate.

INSTALLING NEW SHAFT SEAL

▲ WARNING Before handling shaft seal parts wipe hands clean. Dirt or grease **MAY** damage the seal.

▲ AVERTISSEMENT Se laver les mains avant de manipuler les pièces du joint de l'arbre. La poussière ou la graisse **POURRAIT** endommager le joint.

1. Push seat enclosed in rubber into seal cavity on seal plate. Use a cardboard washer to protect polished surface when pushing against ceramic seat with any object. Be sure to remove cardboard washer.

NOTE: Be careful not to scratch the ceramic surface of the seal seat.

2. Carefully slip seal plate over shaft. Do not disturb seal position in seal plate. The seal plate must be orientated during assembly so the two screw holes are on a horizontal line across the motor shaft (Figure 10). This placement should be done to ensure proper draining and priming.
3. Place rotating shaft seal member in position on impeller and press into place. Take care not to press against polished seal surface.
4. Position impeller on shaft and tighten securely (Figure 11).
5. Secure diffuser to seal plate using the two cap screws. Be sure the arrow on the front of the diffuser is pointing up and the screws are orientated on a horizontal line as described in Step 2.
6. Carefully position pump housing (volute) gasket over the diffuser onto the seal plate. In all shallow well applications care must be taken that the o-ring is clean and properly positioned on the venturi. Cleaning and positioning makes a good seal inside the diffuser when assembled.
7. Assemble the pump housing (volute) to the motor using the four cap screws. Be sure the pump housing (volute) gasket is positioned correctly and tighten the screws securely.

NOTE: Shaft must rotate freely and rear cover should be secured before operation.

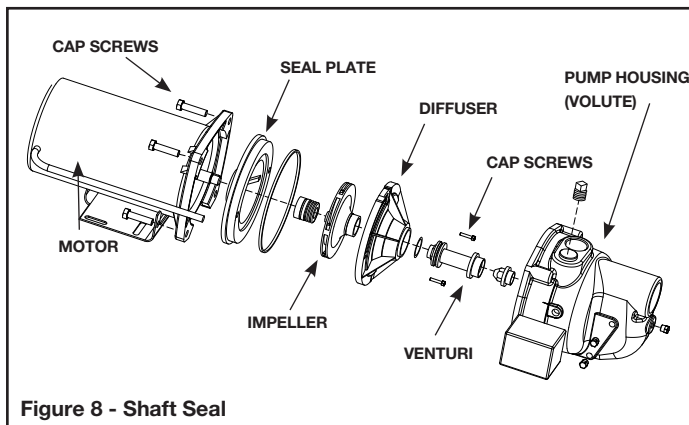

Figure 8 - Shaft Seal

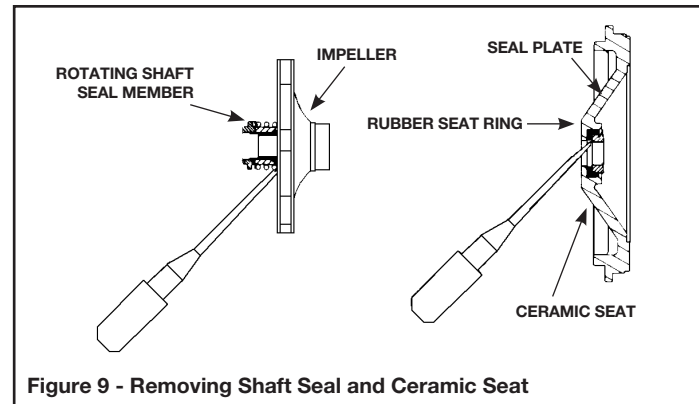

Figure 9 - Removing Shaft Seal and Ceramic Seat

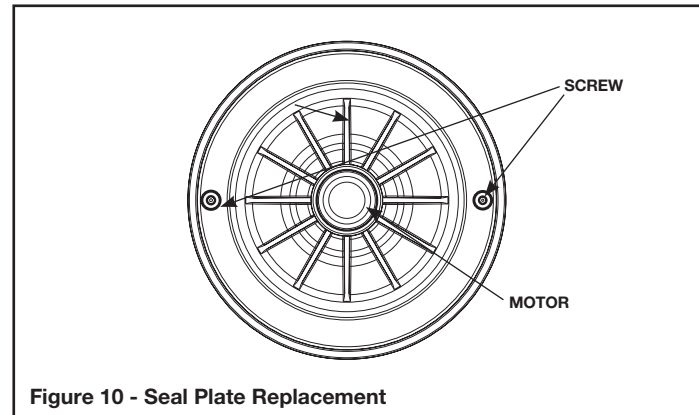

Figure 10 - Seal Plate Replacement

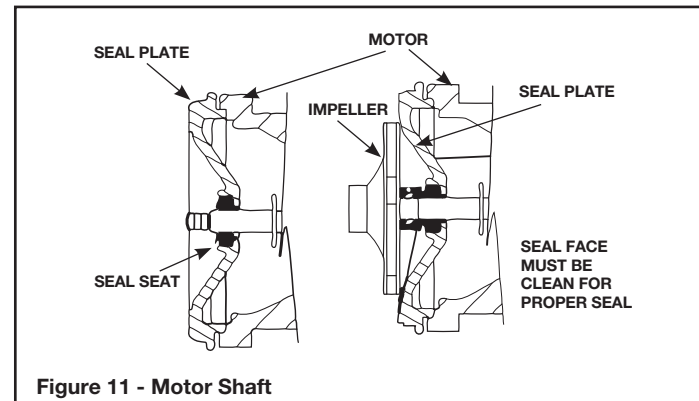

Figure 11 - Motor Shaft

Replacement Part Kit Installation

1. Disconnect all power from the pump
2. Open faucet nearest the tank and allow all of the water to drain from the tank and pump.
3. Remove 4 cap screws, do not disconnect pressure switch.
4. Remove pump housing from pump assembly, move it out of the way.
5. Using a 3/4" socket remove venturi from pump housing
6. Using a 11/16" socket and extension remove nozzle from pump housing
7. Using a 5/16" socket or flat blade screw driver remove the 2 screws from the diffuser on the pump assembly.
8. Remove the diffuser, and remove the rear cover from the back of the motor.
9. Using a 7/16" wrench, hold the motor shaft across its wrench flats while unscrewing the impeller.
10. Remove the shaft seal from the impeller, make sure the stainless steel sleeve comes off the impeller, all you should see on the back of the impeller is the brass colored threaded insert.
11. Remove the ceramic seat and rubber boot part of the seal from the cast iron seal plate.
12. Remove the square cut gasket from the seal plate.
13. Reassemble the pump with new parts in reverse order.
14. Wipe down the seal plate to remove any debris or loose rust.
15. Push the ceramic seat of the shaft seal into the seal plate using the cardboard ring provided to keep the ceramic face clean. You can use a little water or dish soap to lubricate the seal pocket to make assembly easier.

16. Slide the square cut gasket over the flange on the seal plate, make sure not to let the gasket twist.
17. Carefully slip the seal plate over the shaft so as not to disturb seal position in the seal plate. The seal plate must be orientated during assembly so the two holes are on a horizontal line across the motor shaft.
18. Push the bellows side of the shaft seal over the impeller hub, you can use a little water or dish soap to lubricate the impeller hub to make assembly easier.
19. Holding the motor shaft with a 7/16" wrench hand tighten threaded insert of the impeller onto the motorshaft. Lubricate the nose of the impeller with Dow Corning III valve lubricant and sealant or other potable water safe lubricant.
20. Replace the rear cover over the motor end.
21. Reassemble the diffuser, make sure the arrow indicating the top is pointed toward the top of the pump, torque the two screws to 30 ±10 inch pounds.
22. Using the 11/16" socket and extension reassemble the nozzle to the pump housing, torque to 50 ± 10 inch pounds.
23. Reassemble the Venturi to the pump Housing, torque to 50 ±10 inch pounds.
24. Using the (4) cap screws reattach the pump housing and base to the pump body. Torque the screws to 140 ±40 inch pounds.
25. Reattach the plumbing connections, reconnect the power and prime the pump (See section on priming the pump). After reassembling the pump check for leaks. If a leak is detected, repair before using the pump.

Please provide following information:

- Model number
- Serial number (if any)
- Part description and number as shown in parts list

Address any correspondence to:

WAYNE Pumps
 101 Production Drive
 Harrison, OH 45030 U.S.A.

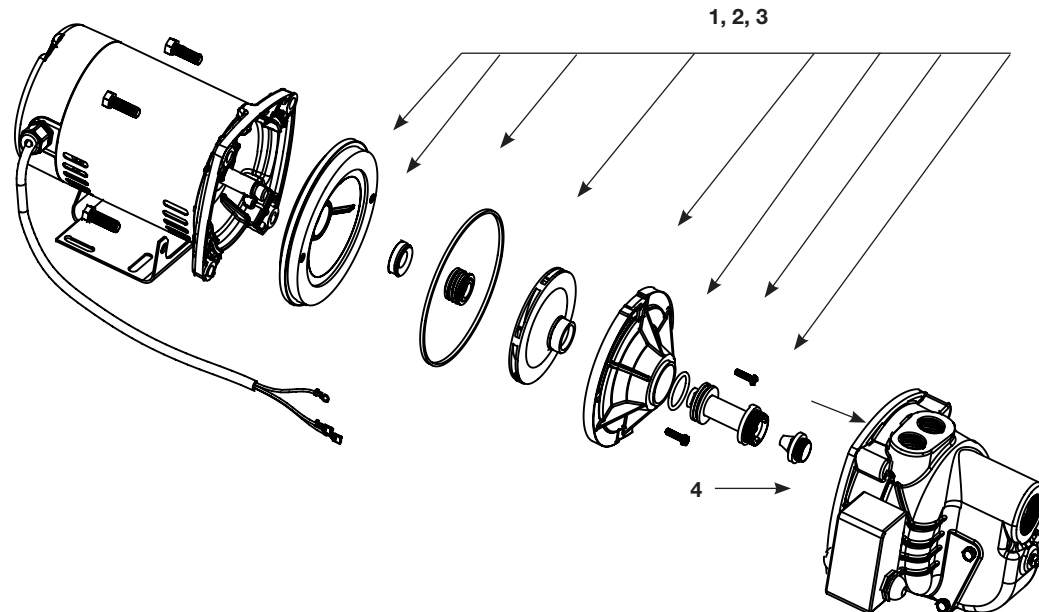

Ref. No.	Description	Part No.	Qty.
1, 2, 3	Kit (Gaskets, impeller, Venturi, Jet Nozzle, Shaft Seal Assembly, Diffuser, Screws)	1/2 HP SWS50 64043-WYN2 3/4 HP SWS75 64044-WYN1 1 HP SWS100 64045-WYN1	1
4	30/50 Pressure Switch Kit	64031-WYN1 (ALL MODELS)	

TROUBLESHOOTING CHART

Symptoms	Possible Cause(s)	Suggested Remedies
Pump will not start or run	<ol style="list-style-type: none"> 1. Power off 2. Blown fuse or tripped breaker 3. Faulty pressure switch 4. Motor overload tripped 5. Low supply voltage 	<ol style="list-style-type: none"> 1. Turn power on or call power company 2. Replace fuse or reset circuit breaker 3. Replace 30/50 pressure switch 4. Let cool. Overload will automatically reset 5. Contact an electrician
Motor hums but won't run	<ol style="list-style-type: none"> 1. Line voltage does not match selector switch 2. Inadequate wiring 3. Damaged or misalignment causing rotating parts to bind 4. Low supply voltage 	<ol style="list-style-type: none"> 1. Check line voltage and voltage selector switch (see Figure 7 on page 8) 2. Rewire 3. Replace or take to service shop for repair 4. Contact an electrician
Overload trips	<ol style="list-style-type: none"> 1. Low supply voltage 2. Damaged or misalignment causing rotatin parts to bind 3. High surrounding temperature 4. Rapid cycling 5. Inadequate wiring 	<ol style="list-style-type: none"> 1. Contact an electrician 2. Replace or take to motor replare shop 3. Provide a shaded, well-ventilated area for pump 4. See pump starts and stops too often section below 5. Rewire
Pump runs but delivers little to no water. NOTE: check to make sure pump is primed before looking for other causes. Unscrew priming plug and see if water is in priming hole.	<ol style="list-style-type: none"> 1. Water level below pump intake 2. Discharge not vented while priming 3. Leak in suction piping 4. Well screen or inlet clogged 5. Clogged nozzle 6. Air volume control disphragm ruptured 7. Foot valve may be clogged or stuck closed 8. Pump not fully primed 9. Water level below maximum lift specification 10. Undersized piping 11. Gaseous well 12. Distorted venturi 13. Incorrect jet for application 14. Undersized pump 15. Pump cavitates, sounds like pumping gravel 16. Low supply voltage 	<ol style="list-style-type: none"> 1. Lower suction pipe further into wall 2. Open faucet to allow air to vent while priming pump 3. Repair or replace to fix leak 4. Clean or relace to remove obstruction 5. Clear obstruction from nozzle 6. Replace air volume control 7. Clean or replace as needed 8. Continue priming, pausing every 5 minutes to cool pump body. Refill pump as needed 9. Select applicable pump and/or jet assembly 10. Replace as needed 11. Install baffle on pump intake to prevent gas from entering system 12. Inspect and replace 13. Purchase a jet matched to your system 14. Increase horsepower of pump 15. Increase suction plumbing diameter or decrease pipe friction 16. Contact an electrician
Pump starts and stops too ofen	<ol style="list-style-type: none"> 1. Water-logged tank (Conventional Tank) 2. Air volume control tubing kinked or clogged 3. Air volume control tubing connected to wrong opening on pump 4. Incorrect tank pressure (pre-charged tank) 5. Ruptured disphragm/bladder (pre-charged tank) 6. Leak in house piping 7. Foot valve or check valve stuck open 8. Motor overload tripping 9. Improperly adjusted or damage pressure switch 	<ol style="list-style-type: none"> 1. Replace tank or air volume control 2. Clean or replace as needed 3. Move to correct pump opening 4. Add or release air as needed 5. Replace tank 6. Locate and repair leak 7. Remove and replace 8. See overload trips section 9. Replace 30/50 pressure switch

⚠ WARNING

ELECTRICAL PRECAUTIONS - Before servicing a pump, ALWAYS shut off the main power breaker and then unplug the pump. Make sure you are NOT standing in water and are wearing insulated protective sole shoes. Under flooded conditions, contact your local electric company or qualifi ed licensed electrician for disconnecting electrical service prior to pump removal.

⚠ AVERTISSEMENT

PRÉCAUTIONS ÉLECTRIQUES - Avant tout entretien ou réparation de pompe, TOUJOURS couper le courant au disjoncteur, puis débrancher la pompe. S'assurer de ne PAS rester debout dans l'eau, et porter des chaussures à semelles de protection isolées. En cas d'inondation, vérifiez auprès de la société locale d'électricité ou d'un électricien agréé qualifié pour couper le service électrique avant le retrait de la pompe.

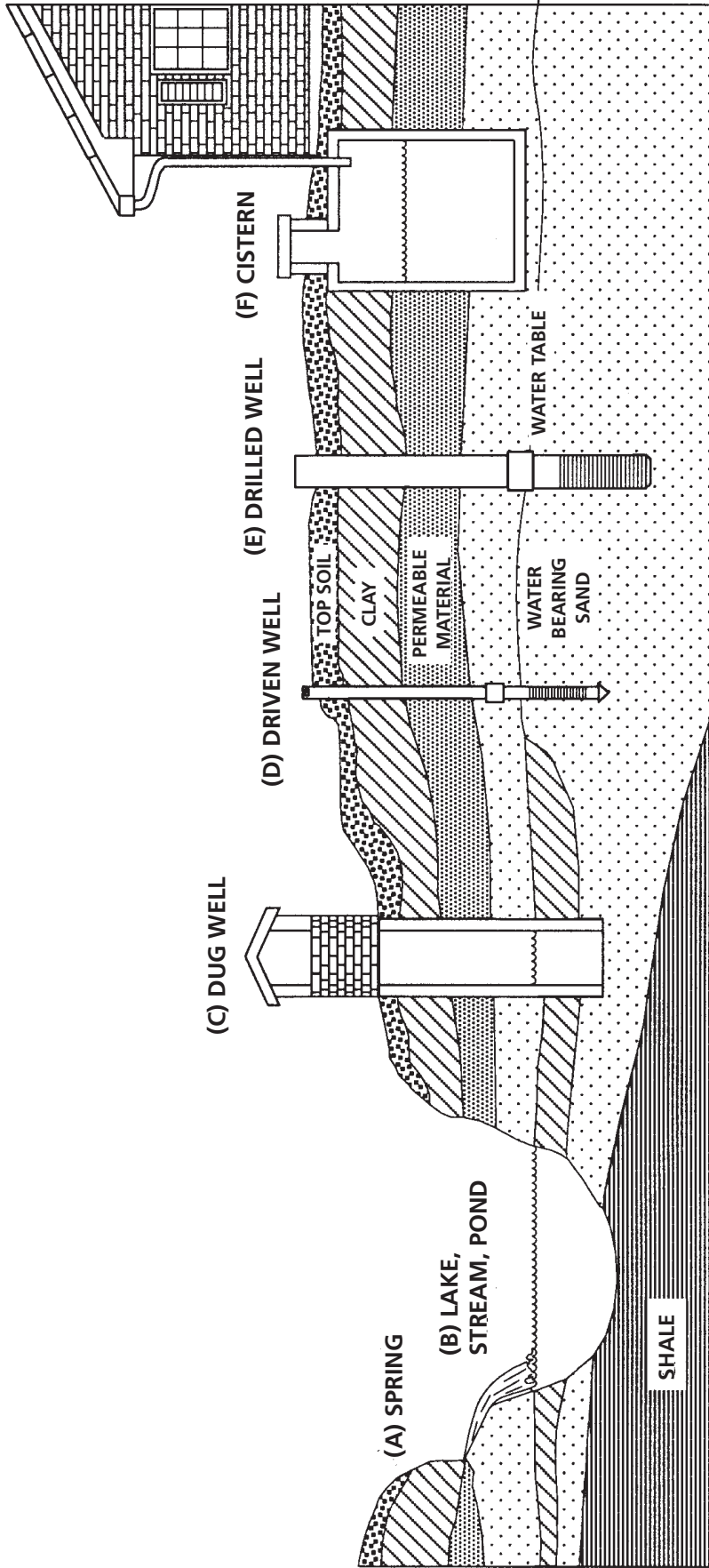

- (A) SPRING:**
A spring that emerges from the ground. Occurs when water in permeable materials is trapped between impermeable material as rock or clay.
- (B) LAKE, STREAM or POND:**
Surface water, unless treated, is usually not safe for human consumption. It may be used for purposes such as washing or irrigation.
- (C) DUG WELL:**
A hole is excavated several feet in diameter to a fairly shallow depth. It is then lined with brick, stone or concrete to prevent cave-in.
- (D) DRIVEN WELL:**
Pipe with a pointed screen is driven into the ground below the water table. The depth is usually less than 50 feet. Available diameters are 1" through 2".
- (E) DRILLED WELL:**
A hole bored into the earth with machinery and lined with pipe. Depths range from a few feet to over 1000 feet. Common well diameters are 2", 3", 4" and 6" for domestic water wells.
- (F) CISTERN:**
An underground tank built to collect rain water from rooftops. The water is not fit for human consumption.

Figure 12 - Well Types

LIMITED WARRANTY

For three years for SWS50, SWS75 and SWS100 models from the date of purchase, from an authorized dealer, WAYNE Pumps will repair or replace, at its option for the original purchaser, any part or parts of its Well Pumps or Water Pumps ("Product") found upon examination by WAYNE Pumps to be defective in materials or workmanship. Please call WAYNE Pumps (800-237-0987) for warranty instructions. Be prepared to provide the model number and the serial number when exercising this warranty. All transportation charges on Products or parts submitted for repair or replacement must be paid by purchaser.

This Limited Warranty does not cover Products which have been damaged as a result of accident, abuse, misuse, neglect, improper installation, improper maintenance, or failure to operate in accordance with WAYNE Pumps written instructions.

THIS WARRANTY IS IN LIEU OF ANY AND ALL OTHER WARRANTIES, OBLIGATIONS OR AGREEMENTS, EXPRESSED OR IMPLIED, INCLUDING ANY IMPLIED WARRANTY OF MERCHANTABILITY OR FITNESS FOR ANY PARTICULAR PURPOSE, AND ANY RIGHTS OR REMEDIES AGAINST ANY PERSON OR ENTITY UNDER THE UNIFORM COMMERCIAL CODE OR OTHERWISE WITH RESPECT TO THE SALE OF THE PRODUCT. THE REMEDIES AND OBLIGATIONS STATED IN THIS WARRANTY ARE THE SOLE AND EXCLUSIVE REMEDIES OF AND OBLIGATIONS TO THE OWNER FOR ANY AND ALL MATTERS ARISING WITH RESPECT TO OR IN ANY WAY CONNECTED WITH THE PRODUCT, REGARDLESS OF THE SOURCE OR PROVIDER OF SUCH GOODS. IN NO EVENT, WHETHER AS A RESULT OF BREACH OF CONTRACT, WARRANTY TORT (INCLUDING NEGLIGENCE) OR OTHERWISE, SHALL WAYNE WATER SYSTEMS OR ANY AFFILIATE BE LIABLE FOR ANY SPECIAL, INCIDENTAL OR CONSEQUENTIAL DAMAGES.

You **MUST** retain your purchase receipt along with this form. In the event you need to exercise a warranty claim, you **MUST** send a **copy** of the purchase receipt along with the material or correspondence. Please call WAYNE Pumps (800-237-0987) for return authorization and instructions.

DO NOT MAIL THIS FORM TO Wayne Water Systems. Use this form only to maintain your records.

MODEL NO. _____ SERIAL NO. _____ INSTALLATION DATE _____

ATTACH YOUR RECEIPT HERE