

PONDMASTER POND-MAG[®] MAGNETIC DRIVE WATER PUMPS

PM 950 - ITEM# 02720

Max. Watts/Amps	93/1.33
Inlet	3/4" FPT
Outlet	3/4" MPT
Cord Length	18'
Dimensions (L x W x H)	5.5" x 3.4" x 5"



PM 950



PM 1200 - ITEM# 02722

Max. Watts/Amps	110/1.5
Inlet	3/4" FPT
Outlet	3/4" MPT
Cord Length	18'
Dimensions (L x W x H)	6.4" x 4.5" x 4.6"

PM 1800 - ITEM# 02728

Max. Watts/Amps	145/1.55
Inlet	3/4" FPT
Outlet	3/4" MPT
Cord Length	18'
Dimensions (L x W x H)	6.4" x 4.5" x 4.6"

PM 2400 - ITEM# 02750

Max. Watts/Amps	237/2.2
Inlet	1" FPT
Outlet	1" MPT
Cord Length	18'
Dimensions (L x W x H)	7.5" x 4.0" x 4.6"



PM 3600



PM 3600 - ITEM# 02755

Max. Watts/Amps	256/3.0
Inlet	1" FPT
Outlet	1" MPT
Cord Length	18'
Dimensions (L x W x H)	7.5" x 4.0" x 4.6"

Model	Item #	Watts	Flow at 1'	Flow at 2'	Flow at 3'	Flow at 4'	Flow at 5'	Flow at 6'	Flow at 7'	Flow at 8'	Flow at 9'	Flow at 10'	Flow at 15'	Shut-Off (Feet)
PM 950	02720	93	1010	930	900	840	770	710	650	600	530	475	-	13' 7"
PM 1200	02722	110	1190	1130	1065	940	900	840	795	730	630	570	-	13' 7"
PM 1800	02728	145	1300	1240	1170	1130	1040	1015	925	880	810	775	470	16' 6"
PM 2400	02750	237	2400	2350	2190	2030	1860	1730	1645	1510	1395	1380	830	17' 1"
PM 3600	02755	256	3060	2885	2775	2670	2595	2480	2365	2295	2205	2170	1615	22' 6"

PONDMASTER HYDRO-AIR[®] SUBMERSIBLE WATER & AIR PUMP

PONDMASTER

THE PONDMASTER HYDRO-AIR SUBMERSIBLE WATER & AIR PUMP is a unique patented design that allows water flow and aeration to be produced by one pump. With a dual-ended impeller design, this energy-efficient design fulfills two functions with one product. The pump is completely epoxy-encased so there's never a fear that it will contaminate the water with harmful oils or chemicals.

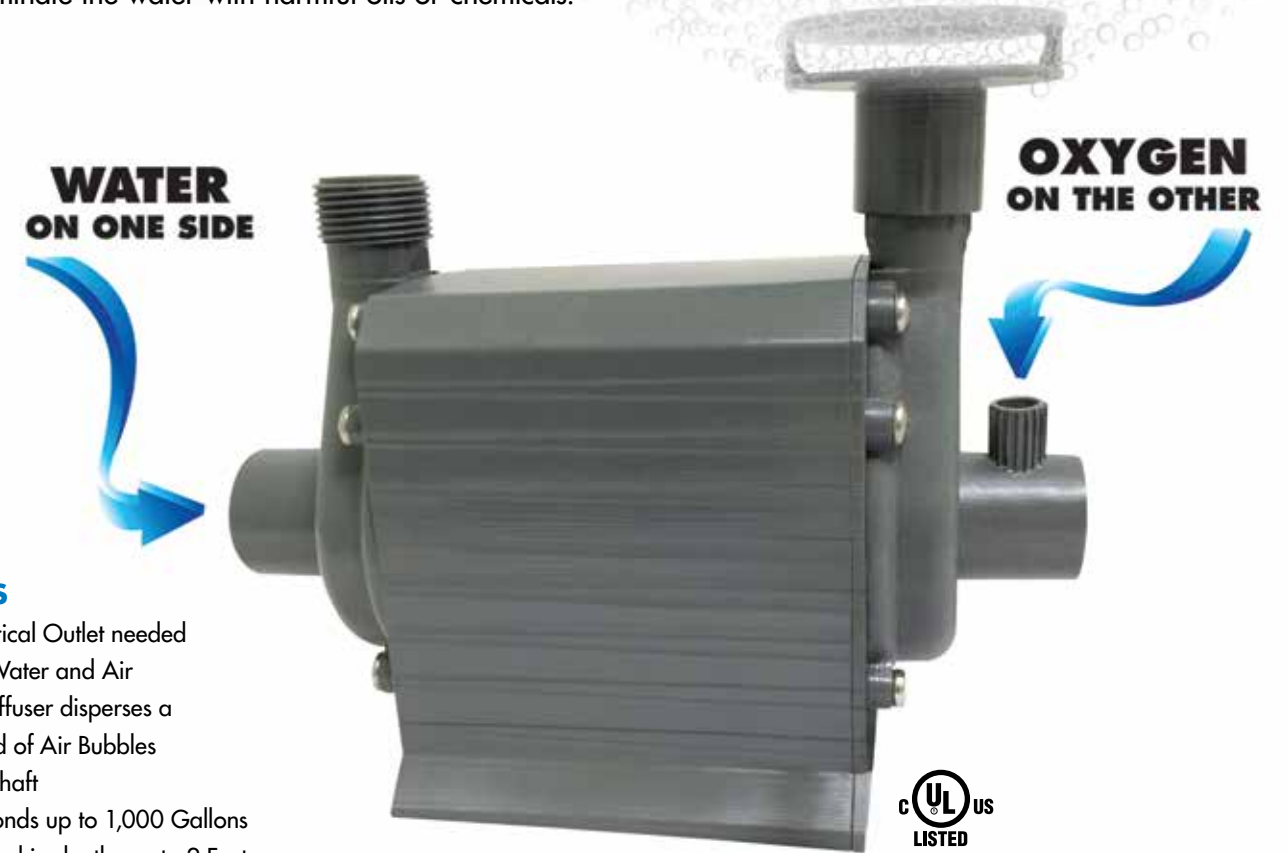

FEATURES

- One Electrical Outlet needed for both Water and Air
- Custom Diffuser disperses a wide band of Air Bubbles
- Ceramic Shaft
- Aerates Ponds up to 1,000 Gallons
- Can be used in depths up to 2-Feet
- Pumps up to 1400 Gallons per hour
- (2) Pre-Filters Included
- 1 Year Limited Warranty

HYDRO-AIR SUBMERSIBLE WATER & AIR PUMP ITEM# 02795

ON WATER PUMP SIDE

- 3/4" FPT Inlet
- 3/4" MPT Outlet

ON AIR PUMP SIDE

- Requires 1/2" Flexible PVC Tubing on the Inlet (sold separately)
- Air Diffuser on the Outlet (included)

