

## UP16 SERIES - 1/6 HP

### APPLICATIONS

Commercial, industrial, home dewatering, and water transfer uses

### FEATURES

- 1/6 hp oil-free motor with overload protection
- Designed for continuous duty
- Pumps down to 1/4"
- Removable filter screen for easy cleaning
- Garden hose adapter
- 120 °F (49 °C) liquid temperature rating
- cCSAus listed



### SERIES SPECIFICATIONS

Volts	Hz	Amps		Watts	Performance (GPM @ Height in Feet)			Shut-Off (ft)	PSI
		FLA	Start		5'	10'	15'		
115	60	2.1	5	200	20	14	7	19	8.2

  

Item No.	Model	HP	Volts	Switch Type/Operation	Cord	Weight
620137	UP16	1/6	115	Manual	10' 3 m	8 lbs 3.63 Kg

# UTILITY PUMPS

## UP16 SERIES - 1/6 HP

### ENGINEERING DATA

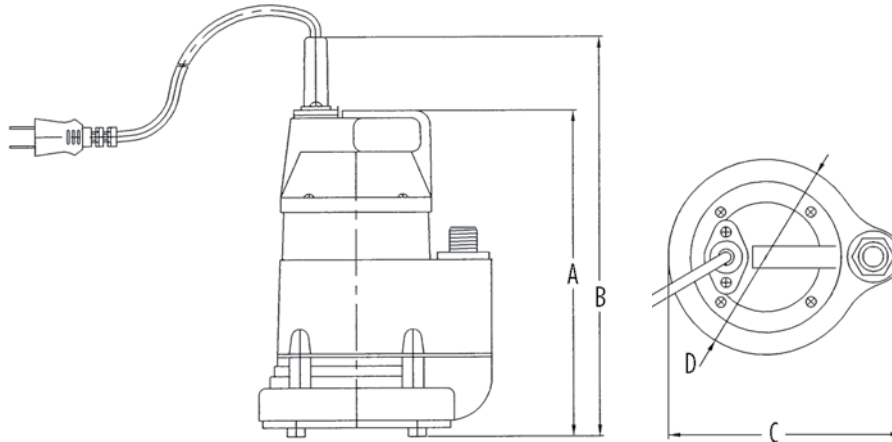

A	B	C	D
8.7"	10.67"	6.2"	5.2"
22.10 cm	27.10 cm	15.75 cm	13.21 cm

### PERFORMANCE DATA

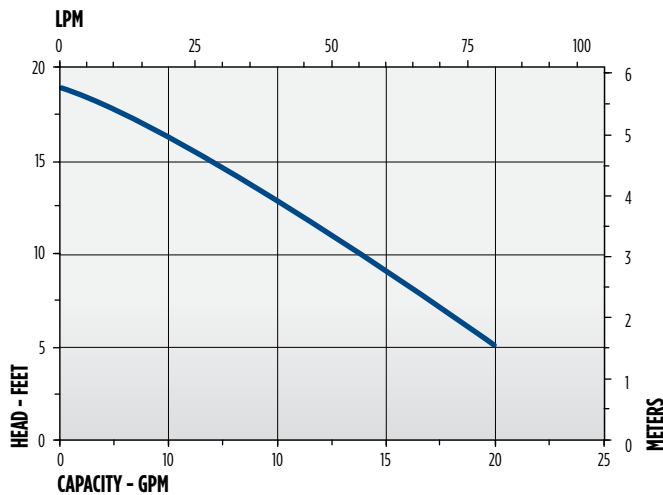

### CONSTRUCTION

<b>Motor Housing</b>	Aluminum
<b>Impeller Material</b>	Thermoplastic
<b>Impeller Type</b>	Semi-open
<b>Volute</b>	Aluminum
<b>Motor Shaft</b>	Stainless steel
<b>Shaft Seal</b>	Lip
<b>Fasteners</b>	Stainless steel
<b>Bearings</b>	Upper and lower ball bearings
<b>Power Cord</b>	SJTW 18/3