

#### ENGINE

- Deutz TD 2.9 L4 – water-cooled, naturally aspirated diesel engine
  - 49 hp @ 2600 rpm
  - 4 cylinder
  - 2.9 Liter displacement
  - DOC only for exhaust after treatment
  - EPA Final Tier 4 approved
  - Steel, single wall fuel tank
    - 113 gal. (428 L) capacity / 100 gal. (379 L) usable
- Fuel consumption at prime: 100% - 2.30 gph (8.71 Lph)
- Cooling system capable of operating at 120°F (49°C) ambient
- Disposable air filter – paper element
- 950 CCA wet cell battery
- 95 Amp alternator
- Low coolant warning/shutdown

#### PUMP

- Cornell 4STX Self Prime Centrifugal Pump
- 4.00" NPTF – suction & discharge connection
- Ductile Iron ASTM A536, 65-45-12 volute casing
- Ductile Iron ASTM A536, 100-70-03 impeller
- Self-cleaning wear plate – mild steel
- Impeller is a 2 vane, semi-open design
- Single mechanical seal, John Crane Type 2, with tungsten carbide vs silicon carbide faces
- Replaceable wear plate
- Pump shaft – 17-4 PH Stainless steel

**PUMP PERFORMANCE**

- Pump maximum output – 900 gpm (3,407 Lpm)
- Lift suction – 28 ft. (8.5 m)
- Maximum diameter of solids – 3.00” (76.2 mm)
- Impeller diameter: 9.75 inches ( cm)
- Maximum Efficiency (BEP Percent) – 55%
- BEP Flow – 682 gpm (Lpm) @ 107ft. TDH
- Total dynamic head – 150 ft (m)
  
- Duty Points:
  - 500 gpm @ 52-ft TDH @ 1500 RPM, 55% efficiency, NPSHR 9.02 ft
  - 753 gpm @ 98.6-ft TDH @ 2100 RPM, 55% efficiency, NPSHR 17.2 ft

**FLOW CHART / PUMP CURVE**

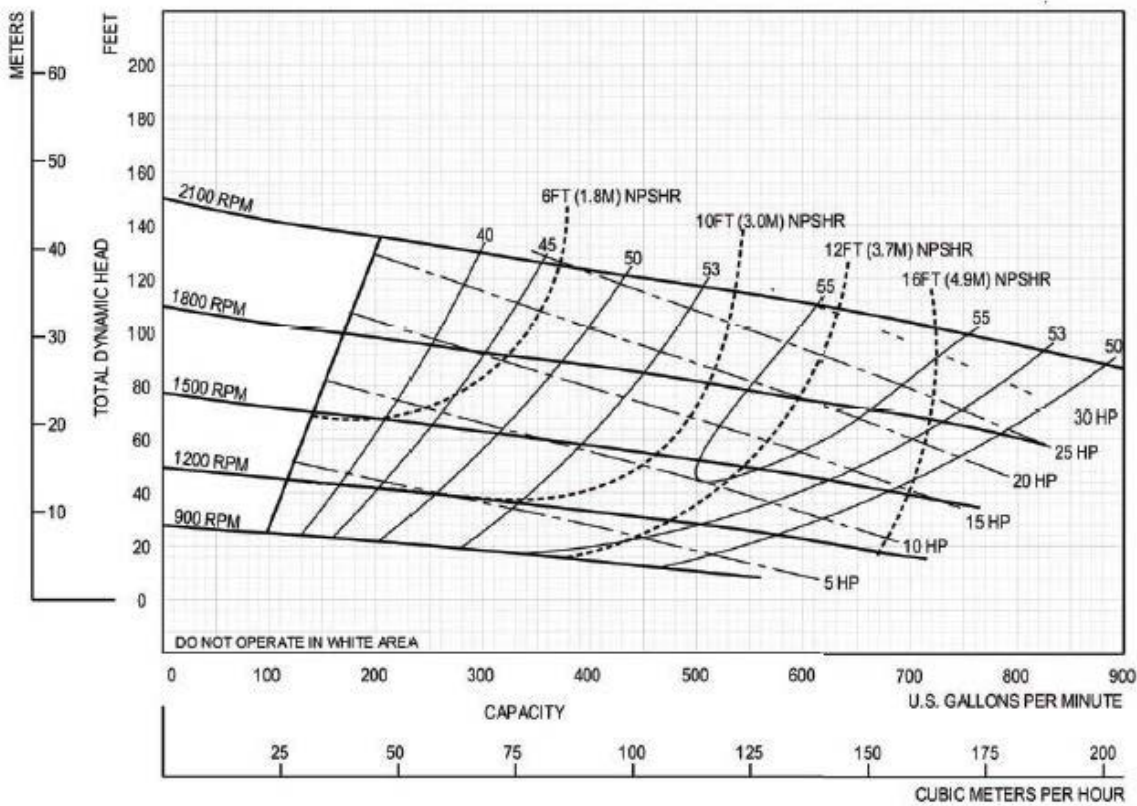

### SYSTEM CONTROLS

- White LED lighting control panel lighting
- Standard controller – LOFA CP750
  - Large, backlit 4.3 in. (109 mm) LCD display
    - Displays engine temp, engine speed, fuel level, engine hrs., coolant temp, and oil pressure
  - Advanced automatic start/stop control for use with two-switch inputs and 4-20mA transducer
  - Configurable high and low set points control start/stop operation
  - Alarm output to signal start warning or shutdown conditions
  - Heavy-duty IP64 water-resistant key switch with booted key
  - RS485 serial interface for auxiliary equipment
  - Electronic e-stop with red LED engagement indicator light

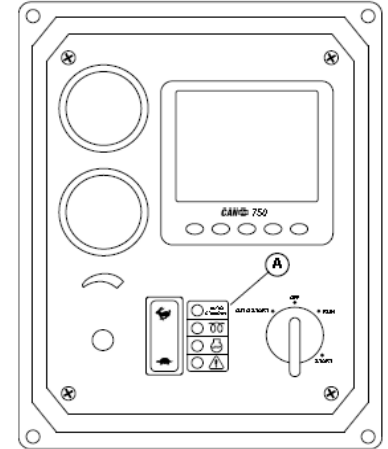

### TRAILER

- Flip-tongue design
- Bolt-on, replaceable front tongue mounting plate
- DOT approved LED tail, side, brake, and directional lights
- (4) transportation tie downs capable of handling 3 in. (76.2 mm) trailer straps
- Safety chains with spring loaded safety hooks
- 2 in. (50.8 mm) adjustable ball hitch
- 6000 lb. (2722 kg) torsion axle with surge brakes
- 3000 lb. (1361 kg) tongue jack with footplate
- (2) 2000 lb. (907 kg) side wind jacks, with option to add up to (4)
- ST225/75R15 tubeless tires – 8 ply
- UV & fade resistant, high temperature cured, black polyester power paint
- Central lifting point
- Document holder with operating manual including the AC/DC wiring diagrams

**WEIGHT & DIMENSIONS**

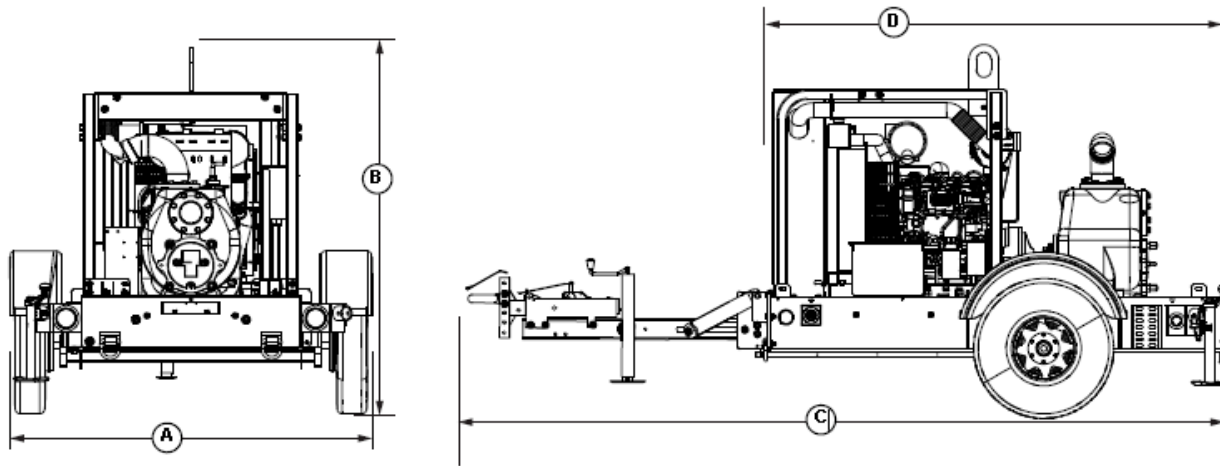

A	B	C	D
75.00 in.(1.905 m)	73.88 in. (1.877 m)	150.12 in. (3.813 m)	98.00 in. (2.489 m)

- Trailer Mounted
  - Dry weight: 3,714 lbs. (1,685 kg)
  - Operating weight: 4,528 lbs. (2,054 kg)
  - Dimensions: 150.12 x 75.00 x 73.88 in. (3.81 x 1.91 x 1.88 m)
- Skid Mount
  - Dry weight: 3,094 lbs. (1,403 kg)
  - Operating weight: 4,528 lbs. (2,054 kg)
  - Dimensions: 91.16 x 66.60 x 61.50 in. (2.32 x 1.69x 1.56 m)

**WARRANTY**

2 Years / 2000 Hours; See warranty policy for complete details