

INTRODUCTION

Congratulations on your selection of a Honda multi-purpose pump! We are certain you will be pleased with your purchase of one of the finest pumps on the market.

We want to help you get the best results from your new pump and to operate it safely. This manual contains the information on how to do that; please read it carefully.

We suggest you read the *DISTRIBUTOR'S LIMITED WARRANTY* (page 17) and *EMISSION CONTROL SYSTEM WARRANTY* (page 18) to fully understand coverage and your responsibilities of ownership.

When your pump needs scheduled maintenance, keep in mind that an authorized Honda servicing dealer is specially trained in servicing Honda pumps and is supported by the parts and service divisions of American Honda. Your Honda dealer is dedicated to your satisfaction and will be pleased to answer your questions and concerns.

Keep this owner's manual handy so that you can refer to it at any time. This owner's manual is considered a permanent part of the pump and should remain with the pump if resold.

The information and specifications included in this publication were in effect at the time of approval for printing. American Honda Motor Co., Inc. reserves the right, however, to discontinue or change specifications or design at any time without notice and without incurring any obligation whatever. No part of this publication may be reproduced without written permission.

SAFETY MESSAGES

Your safety and the safety of others are very important. We have provided important safety messages in this manual and on the pump. This information alerts you to potential hazards that could hurt you or others. Please read these messages carefully.

Of course, it is not practical or possible to warn you about all the hazards associated with operating or maintaining a multi-purpose pump. You must use your own good judgment.

You will find important safety information in a variety of forms:

- **Safety Labels** – on the pump.
- **Instructions** – how to use this pump correctly and safely.
- **Safety Messages** – preceded by a safety alert ⚠ symbol and one of three signal words: DANGER, WARNING, or CAUTION. These signal words mean:

⚠ DANGER

You WILL be KILLED or SERIOUSLY HURT if you don't follow instructions.

⚠ WARNING

You CAN be KILLED or SERIOUSLY HURT if you don't follow instructions.

⚠ CAUTION

You CAN be HURT if you don't follow instructions.

Each message tells you what the hazard is, what can happen, and what you can do to avoid or reduce injury.

- **Damage Prevention Messages** – You will also see other important messages that are preceded by the word NOTICE. This word means:

NOTICE

Your pump or other property can be damaged if you don't follow instructions.

HONDA

OWNER'S MANUAL WMP20X



WARNING:



The engine exhaust from this product contains chemicals known to the State of California to cause cancer, birth defects, or other reproductive harm.

CONTENTS

INTRODUCTION	1	STORAGE	11
SAFETY MESSAGES.....	1	STORAGE PREPARATION.....	11
PUMP SAFETY	2	PLACING IN STORAGE	12
IMPORTANT SAFETY INFORMATION.....	2	REMOVAL FROM STORAGE	12
SAFETY LABEL LOCATIONS	2	TAKING CARE OF UNEXPECTED	
CONTROL LOCATIONS	3	PROBLEMS	13
BEFORE OPERATION.....	3	TECHNICAL INFORMATION.....	13
IS YOUR PUMP READY TO GO?.....	3	SERIAL NUMBER LOCATIONS ..	13
OPERATION.....	4	CARBURETOR	
SAFE OPERATING PRECAUTIONS.....	4	MODIFICATION FOR HIGH	
APPROVED LIQUIDS	5	ALTITUDE OPERATION.....	14
PUMP PERFORMANCE	5	EMISSION CONTROL SYSTEM ..	14
STARTING THE ENGINE	6	AIR INDEX	14
STOPPING THE ENGINE	6	SPECIFICATIONS	15
SERVICING YOUR PUMP	7	CONSUMER INFORMATION	16
MAINTENANCE SAFETY	7	REPLACEMENT PARTS,	
MAINTENANCE SCHEDULE.....	7	OPTIONAL EQUIPMENT, AND	
REFUELING	8	SERVICE ITEMS	16
ENGINE OIL.....	8	DEALER LOCATOR INFORMATION	16
AIR CLEANER	9	CUSTOMER SERVICE	
SPARK PLUG	10	INFORMATION	16
SPARK ARRESTER		DISTRIBUTOR'S LIMITED	
(OPTIONAL EQUIPMENT)	10	WARRANTY.....	17
TRANSPORTING	11	EMISSION CONTROL SYSTEM	
BEFORE LOADING	11	WARRANTY.....	18
LOADING AND UNLOADING	11		

PUMP SAFETY

This chapter explains what you need to know to operate your pump safely.

IMPORTANT SAFETY INFORMATION

Most injuries or property damage can be prevented if you follow all instructions in this manual and on the pump. The most common hazards are discussed below, along with the best way to protect yourself and others.

Keep Shields in Place

Guards and shields are designed to protect you from being hurt by hot or moving parts. For your safety and the safety of others, keep all shields in place when the engine is running.

Wear Protective Clothing

Wearing protective clothing will reduce your risk of injury. Heavy-duty gloves protect your hands. While the sound level of the pump is well within safe limits, hearing protection will further protect your hearing.

Turn Engine Off When Not Pumping

If you need to leave the pump for any reason, always turn the engine OFF.

Operator Responsibility

It is the operator's responsibility to provide the necessary safeguards to protect people and property against chemical leakage. Refer to the handling instructions provided by the manufacturer of the chemical before operating the pump.

Know how to stop the pump quickly in case of emergency. Understand the use of all controls and connections.

Be sure that anyone who operates the pump receives proper instruction. Do not let children operate the pump. Keep children, pets, and bystanders away from the area of operation.

Pump Operation

Do not use for pumping liquids for human consumption.

Never pump flammable liquids such as gasoline or fuel oils. An explosion may result, causing serious injury.

Pump only those chemicals listed in the *APPROVED LIQUIDS* table on page 5 of this manual. Pumping chemicals that are not listed may result in damage to the pump or injury to the operator.

Operate the pump on a level surface. If the engine is tilted, fuel may spill.

Do not enclose the pump in any structure.

Fuel vapors are extremely flammable and may ignite after the engine has started. Make sure that any spilled fuel has been wiped up before starting the pump. Keep flammable materials away from the pump.

Refuel With Care

Gasoline is extremely flammable, and gasoline vapor can explode. Refuel outdoors, in a well-ventilated area, with the engine stopped and allowed to cool, and the pump on a level surface. Do not overfill the fuel tank. Never smoke near gasoline, and keep other flames and sparks away. Always store gasoline in an approved container. Make sure that any spilled fuel has been wiped up before starting the engine.

Hot Exhaust

The muffler becomes very hot during operation and remains hot for a while after stopping the engine. Be careful not to touch the muffler while it is hot. Let the engine cool before transporting the pump or storing it indoors.

To prevent fire hazards, keep the pump at least 3 feet (1 meter) away from building walls and other equipment during operation. Do not place flammable objects close to the engine.

Carbon Monoxide Hazards

Exhaust contains poisonous carbon monoxide, a colorless and odorless gas. Breathing carbon monoxide can cause loss of consciousness and may lead to death.

If you run the pump in an area that is confined, or even partly enclosed, the air you breathe could contain a dangerous amount of exhaust gas.

Never run the engine inside a closed garage, house, or confined area.

SAFETY LABEL LOCATIONS

The label shown here contains important safety information. Please read it carefully. This label is considered a permanent part of your pump. If the label comes off or becomes hard to read, contact your authorized Honda pump dealer for a replacement.

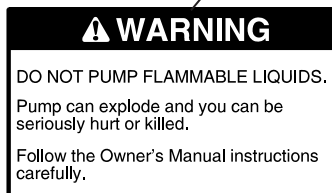
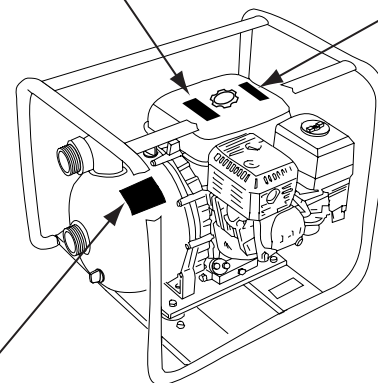
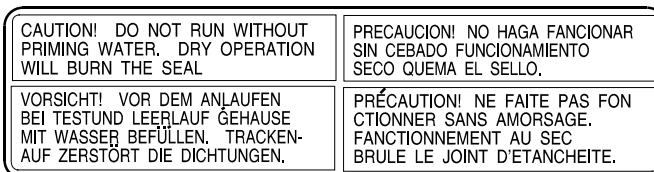

CONTROL LOCATIONS

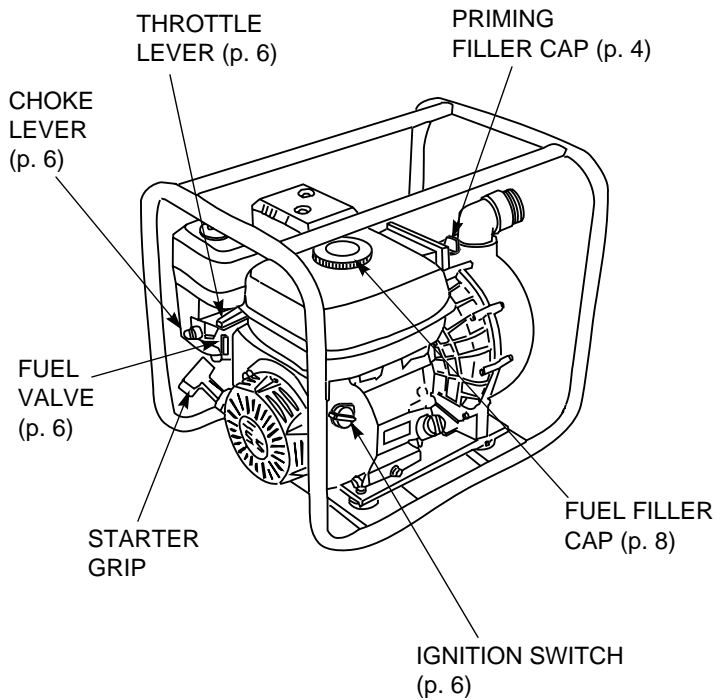

BEFORE OPERATION

Your safety is your responsibility. A little time spent in preparation will significantly reduce your risk of injury.

Read and understand this manual. Know what the controls do and how to operate them.

Familiarize yourself with the pump and its operation before you begin using it. Know how to quickly shut off the engine in case of an emergency.

Be familiar with any safety precautions that are needed to properly pump the chemicals that are listed on page 5.

IS YOUR PUMP READY TO GO?

For your safety, and to maximize the service life of your equipment, it is very important to take a few moments before you operate the pump to check its condition. Be sure to take care of any problem you find, or have your servicing dealer correct it, before you operate the pump.

⚠ WARNING

Improperly maintaining this pump, or failing to correct a problem before operation, could cause a malfunction in which you could be seriously injured.

Always perform a pre-operation inspection before each operation, and correct any problem.

Before beginning your pre-operation checks, be sure the pump is on a level surface and the ignition switch is in the OFF position.

Check the General Condition of the Pump

- Look around and underneath the pump for signs of oil or gasoline leaks.
- Remove any dirt or debris, especially around the engine, muffler, and recoil starter.
- Look for signs of damage.
- Check that all nuts, bolts, screws, hose connectors, and clamps are tightened.
- Keep all shields and covers in place while operating the pump.
- Check the general condition of the hoses. Be sure the hoses are in serviceable condition before connecting them to the pump.

Check the Engine

- Check the oil level (page 8).
- Check the air cleaner (page 9).
- Check the fuel level (page 8). Starting with a full tank will help to eliminate or reduce operating interruptions for refueling.

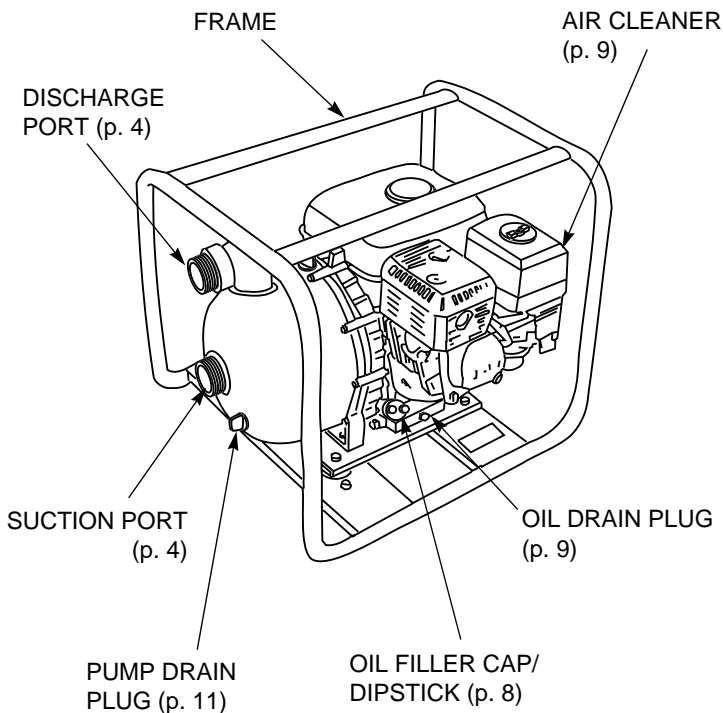

OPERATION

SAFE OPERATING PRECAUTIONS

Before operating the pump for the first time, please review *IMPORTANT SAFETY INFORMATION* (page 2) and *BEFORE OPERATION* (page 3).

For your safety, do not start or operate the engine in an enclosed area, such as a garage. Your engine's exhaust contains poisonous carbon monoxide gas, which can collect rapidly in an enclosed area and cause illness or death.

Suction Hose Connection

Use a commercially available hose, hose connector, and hose clamps. The suction hose must be reinforced with a non collapsible wall or wire braided construction to prevent suction hose collapse. Keep the pump as close to the liquid to be pumped as possible. Avoid bends and sharp turns. Pump performance is best when the pump is not far above the liquid level and the hose is kept straight. Self-priming time is also proportional to the suction hose length. Using a longer suction hose will increase the self-priming time.

Tighten the hose connector to the suction hose with a hose clamp to prevent air leakage and loss of suction. Verify that the connector sealing washer is installed and in good condition. A loosely connected suction hose will reduce pump performance and self-priming ability.

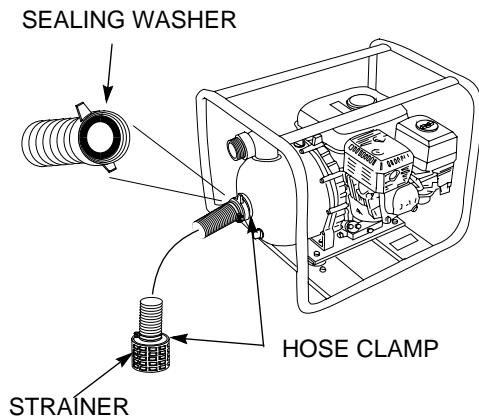

The strainer provided with the pump should always be attached to the end of the suction hose with a hose clamp as shown.

The strainer will prevent debris from entering the pump, preventing clogging or damage to the pump. Clean the strainer of any debris.

Discharge Hose Connection

Use a commercially available hose, hose connector, and hose clamp. A short, large diameter hose will provide lower fluid friction and improve pump efficiency. A long or small diameter hose increases fluid friction and reduces pump output.

Tighten the hose clamp to prevent the hose from disconnecting under high pressure.

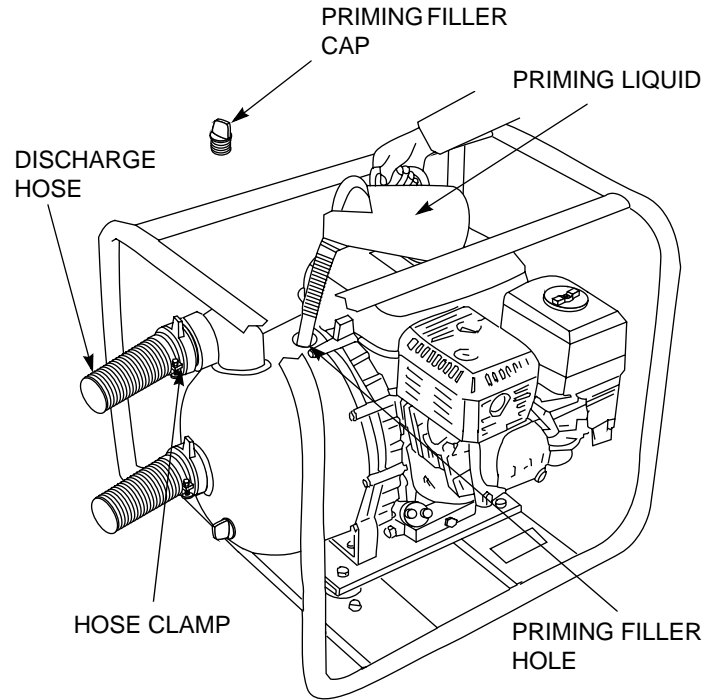

If the discharge hose must run across a roadway, the hose should cross the roadway perpendicular to traffic flow. Also, heavy boards should be placed next to the hose so the motor vehicle weight does not shut off the discharge as vehicles cross over the hose.

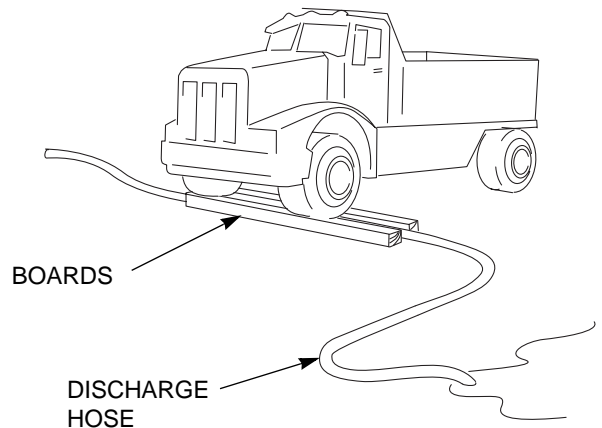

Driving over a discharge hose while the pump is running, or even possibly when the pump is stopped, may cause pump case failure.

Pump Priming

Remove the priming filler cap and completely fill the pump chamber with water before starting the engine. Replace the priming filler cap.

NOTICE

Operating the pump dry will destroy the pump seal.

- *Ensure the pump chamber is full of liquid and the suction hose strainer is submerged in the liquid to be pumped.*
- *If the unit has been operated dry, stop the engine immediately and allow the pump to cool before adding priming liquid.*

APPROVED LIQUIDS

The following is a list of chemicals that the multi-purpose pump is capable of pumping. The operator *must* verify that the liquid that is to be pumped is on these lists. After each use, drain the pump chamber into a suitable container and flush with fresh water.

DO NOT PUMP LIQUIDS FOR HUMAN CONSUMPTION.

⚠ WARNING

Chemicals can cause burns or serious injury.

Wear protective clothing and eye protection when handling chemicals.

Follow the chemical manufacturer's handling procedures.

NOTICE

Pumping liquids that are not listed may damage the pump.

Agricultural Chemicals

Aatrex	Dual	N-Serve 24
Amiben	Eradicane	Phosphoric Acid Solutions
Ammonium Thiosulfate	Extrazine	Poly-N
Banvel	Larsban	Ranger
Basagran	Lasso	Round-up
Bicep	URAN Solutions	Sutan
Bladex	Modown	Treflan
		Vernam

Industrial Chemicals

Acetic Acid, 20%	Glycerine (Glycerol)	Sodium Acetate
Aluminum Sulfate	Lactic Acid	Sodium Bicarbonate
Ammonium Nitrate	Lead Acetate	Sodium Bisulfate
Ammonium Sulfate	Magnesium Chloride	Sodium Bisulfite
Barium Sulfate	Magnesium Nitrate	Sodium Carbonate, 10%
Borax (Sodium Borate)	Magnesium Sulfate	Sodium Chlorate
* Calcium Chloride	Maleic Acid	Sodium Chloride
Citric Acid	Nickel Chloride	Sodium Nitrate
Copper Sulfate	Nickel Sulfate	Sodium Silicate
Detergents (General)	Oleic Acid	Sodium Sulfate
Ethylene Glycol	Phosphoric Acid, 0-80%	Stearic Acid
Fatty Acids	Potassium Carbonate	Sulfuric Acid, 0-29%
Ferric Nitrate	Potassium Chloride	Tartaric Acid
Ferric Sulfate	Potassium Nitrate	Vinegar
Ferrous Sulfate	Potassium Sulfate	Water (Clear)
Formaldehyde, 40%	Soaps (neutral)	Water (Salt)
		Zinc Sulfate

* Temperature does not exceed 80°F (26°C)

The temperature operating range of the pump is between 20 ~ 130°F (-7 ~ 54°C).

PUMP PERFORMANCE

The maximum pump discharge capacity is determined when pumping clear water at 0 ft (0 meters) total head and at sea level. As the total head (discharge head + suction head) increases, pump discharge capacity decreases (see figure below). If the pump is used at higher elevations, pump discharge capacity may also decrease. Other factors affecting pump discharge capacity are:

- The type of chemical being pumped
- The length and type of the suction and discharge hose used

Pump Performance (Maximum with clear water)	
Total head	105 ft (32 m)
Suction head	26 ft (8 m)
Discharge capacity	220 gal/min (833 ℓ/min)
Self-priming time	65 sec at 16.4 ft (5 m)
Pressure	45 psi (310 kPa)

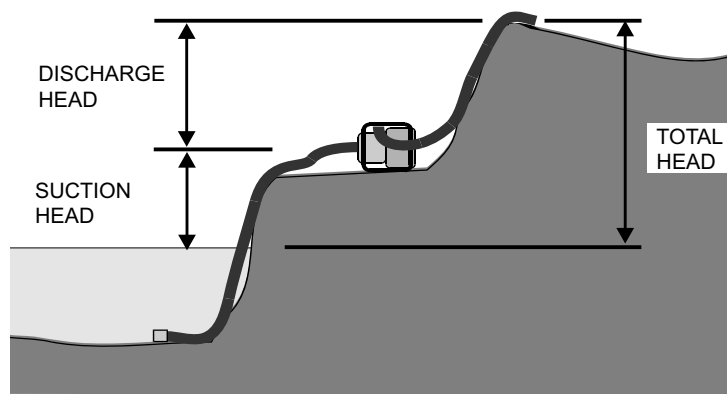

Oil Alert® System

The Oil Alert system is designed to prevent engine damage caused by insufficient oil in the crankcase. Before the oil level in the crankcase can fall below a safe limit, the Oil Alert system will automatically shut down the engine (the ignition switch will remain in the ON position).

If the engine stops and will not restart, check the oil level (page 8) before troubleshooting in other areas.

STARTING THE ENGINE

1. Turn the fuel valve to the ON position.

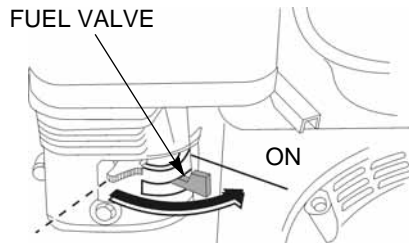

2. Move the choke lever to the CLOSED position.

Do not use the choke if the engine is warm or the ambient temperature is high.

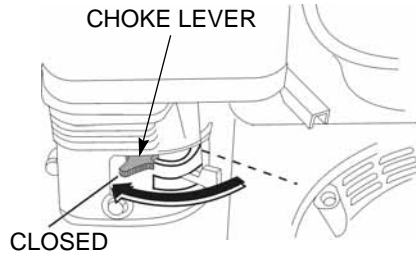

3. Turn the ignition switch to the ON position.

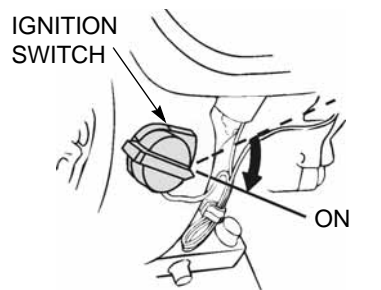

4. Move the throttle lever slightly to the left.

5. Pull the starter grip lightly until resistance is felt, then pull it briskly.

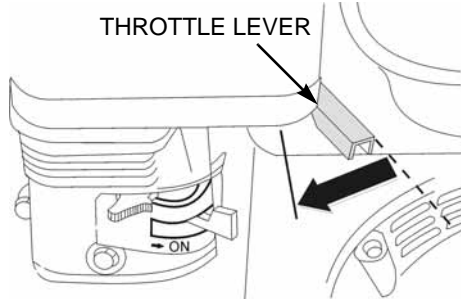

NOTICE

Return the starter grip slowly back to the engine to prevent damage to the starter.

6. As the engine warms up, gradually move the choke lever to the OPEN position.

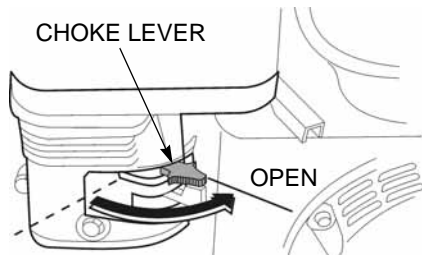

7. Set the throttle to the desired speed to produce the best pumping conditions.

Pump output can be controlled by adjusting the throttle lever to the desired position.

At FULL throttle position, the pump will deliver the highest output volume. Moving the throttle toward the IDLE position will decrease the output volume of the pump.

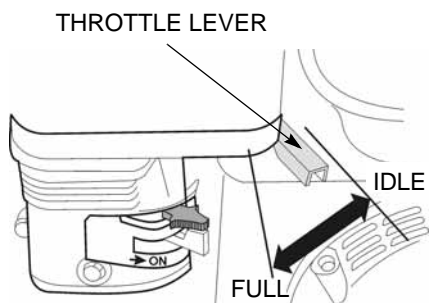

STOPPING THE ENGINE

Emergency

To stop the engine in an emergency, turn the ignition switch to the OFF position.

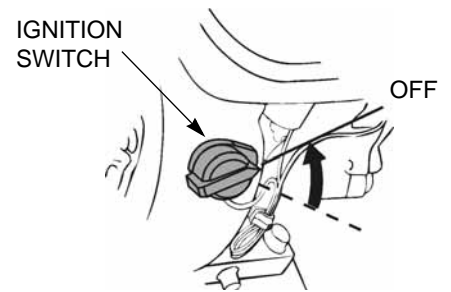

Normal

1. Move the throttle lever fully to the right to the IDLE position.
2. Turn the ignition switch to the OFF position.

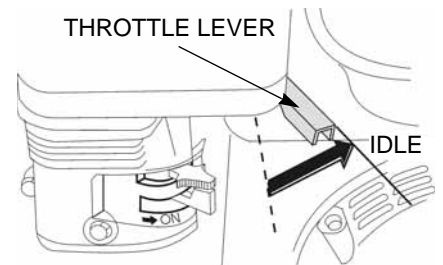

3. Turn the fuel valve to the OFF position.
4. If the pump is not going to be used again for the rest of the day, or is going to be stored for a long period of time, refer to page 12 for procedures on properly storing your pump.

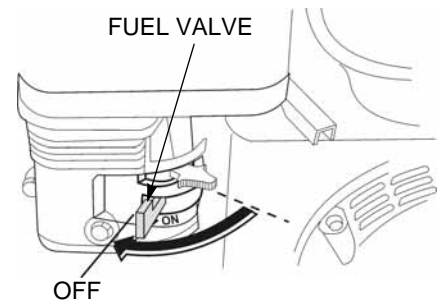

After each use, drain the pump chamber and flush with fresh water.

SERVICING YOUR PUMP

Proper maintenance is essential for safe, economical, and trouble-free operation. It will also help reduce air pollution.

⚠ WARNING

Improper maintenance, or failure to correct a problem before operation, can cause a malfunction in which you can be seriously hurt or killed.

Always follow the inspection and maintenance recommendations and schedules in this owner's manual.

To help you properly care for your pump, the following pages include a maintenance schedule, routine inspection procedures, and simple maintenance procedures using basic hand tools. Other service tasks that are more difficult, or require special tools, are best handled by professionals and are normally performed by a Honda technician or other qualified mechanic.

The maintenance schedule applies to normal operating conditions. If you operate your pump under severe conditions, such as sustained high-load or high-temperature operation, or use in unusually wet or dusty conditions, consult your servicing dealer for recommendations applicable to your individual needs and use.

Remember that an authorized Honda servicing dealer knows your pump best and is fully equipped to maintain and repair it.

To ensure the best quality and reliability, use only new, Honda Genuine parts or their equivalents for repair and replacement.

Maintenance, replacement, or repair of the emission control devices and systems may be performed by any engine repair establishment or individual, using parts that are "certified" to EPA standards.

MAINTENANCE SAFETY

Some of the most important safety precautions follow. However, we cannot warn you of every conceivable hazard that can arise in performing maintenance. Only you can decide whether or not you should perform a given task.

⚠ WARNING

Failure to properly follow maintenance instructions and precautions can cause you to be seriously hurt or killed.

Always follow the procedures and precautions in this owner's manual.

Safety Precautions

- Make sure the engine is off before you begin any maintenance or repairs. This will eliminate several potential hazards:
 - **Carbon monoxide poisoning from engine exhaust**
Operate outdoors away from open windows or doors.
 - **Burns from hot parts**
Let the engine and exhaust system cool before touching.
 - **Injury from moving parts**
Do not run the engine unless instructed to do so.
- Read the instructions before you begin, and make sure you have the tools and skills required.

- To reduce the possibility of fire or explosion, be careful when working around gasoline. Use only a nonflammable solvent, not gasoline, to clean parts. Keep cigarettes, sparks, and flames away from all fuel-related parts.

MAINTENANCE SCHEDULE

Interval ¹	Item
Before each use	Check the engine oil level (page 8) Check the air filter (page 9) Check pump hoses and strainer (page 4)
After each use	Flush the pump chamber (page 11)
First month or 20 hours	Change the engine oil (page 9)
Every 3 months or 50 hours	Clean the air filter ² (page 9) Clean the sediment cup (page 10)
Every 6 months or 100 hours	Change the engine oil ² (page 9) Inspect-adjust the spark plug (page 10) Clean-check the spark arrester (page 10)
Every year or 300 hours	Change the engine oil ² (page 9) Replace the air cleaner paper filter ² (page 9) Replace the spark plug (page 10) Adjust the valve clearance ³ Adjust the idle speed ³ Clean the fuel tank and filter ³
Every 2 years	Check the fuel line and replace if necessary ³

1. For professional commercial use, log hours of operation to determine proper maintenance intervals.
2. Service more frequently when used in dusty areas.
3. These items should be serviced by an authorized Honda servicing dealer, unless you have the proper tools and are mechanically proficient.

Failure to follow this maintenance schedule could result in non-warrantable failures.

REFUELING

Honda recommends using a No-Spill[®] gas can, which meets the demanding requirements of the California Air Resources Board (page 16).

This engine is certified to operate on unleaded gasoline with a pump octane rating of 86 or higher.

Refuel in a well-ventilated area with the engine stopped. If the engine has been running, allow it to cool first. Never refuel the engine inside a building where gasoline fumes may reach flames or sparks.

You may use regular unleaded gasoline containing no more than 10% ethanol (E10) or 5% methanol by volume. In addition, methanol must contain cosolvents and corrosion inhibitors. Use of fuels with content of ethanol or methanol greater than shown above may cause starting and/or performance problems. It may also damage metal, rubber, and plastic parts of the fuel system. Engine damage or performance problems that result from using a fuel with percentages of ethanol or methanol greater than shown above are not covered by warranty.

If your equipment will be used on an infrequent or intermittent basis, please refer to the fuel section of the *STORAGE* chapter (page 11) for additional information regarding fuel deterioration.

⚠ WARNING

Gasoline is highly flammable and explosive.

You can be burned or seriously injured when handling fuel.

- Stop the engine and keep heat, sparks, and flame away.
- Handle fuel only outdoors.
- Wipe up spills immediately.

Never use stale or contaminated gasoline or an oil/gasoline mixture. Avoid getting dirt or water in the fuel tank.

To refuel, remove the fuel tank cap and fill the tank with gasoline to the shoulder of the filler neck. Refuel carefully to avoid spilling fuel. Do not overfill.

After refueling, tighten the fuel tank cap securely.

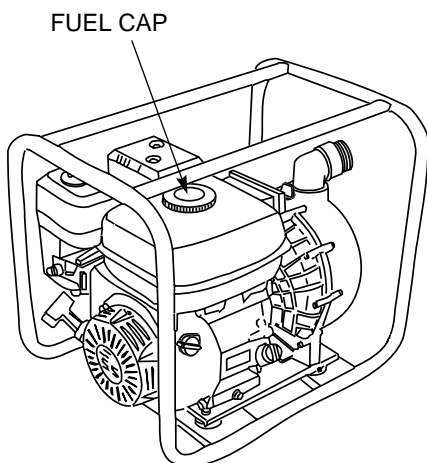

Move the pump at least 10 feet (3 meters) away from the fueling source and site before starting the engine.

NOTICE

Fuel can damage paint and plastic. Be careful not to spill fuel when filling your fuel tank. Damage caused by spilled fuel is not covered by the DISTRIBUTOR'S LIMITED WARRANTY (page 17).

ENGINE OIL

Oil Recommendations

Oil is a major factor affecting performance and service life. Use 4-stroke automotive detergent oil.

SAE 10W-30 is recommended for general use. Other viscosities shown in the chart may be used when the average temperature in your area is within the recommended range.

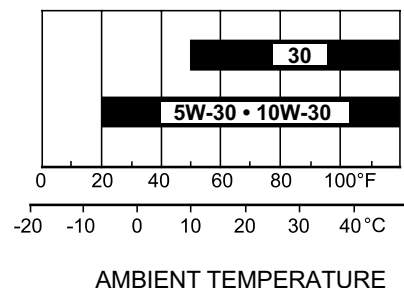

The SAE oil viscosity and service category are in the API label on the oil container. Honda recommends that you use API service category SJ or later oil.

NOTICE

Using nondetergent oil can shorten the engine's service life, and using 2-stroke oil can damage the engine.

Oil Level Check

Check the engine oil level with the engine stopped and in a level position.

1. Remove the filler cap/dipstick and wipe it clean.

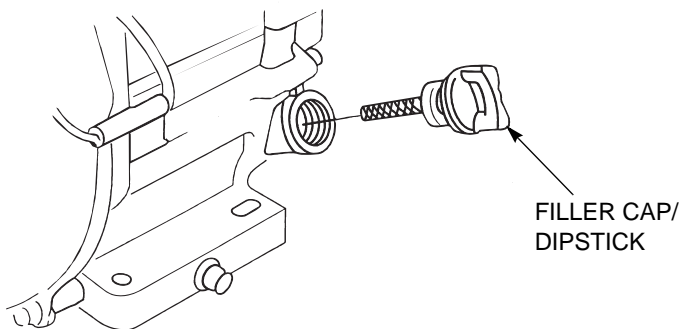

2. Insert and remove the dipstick without screwing it into the filler neck. Check the oil level shown on the dipstick.

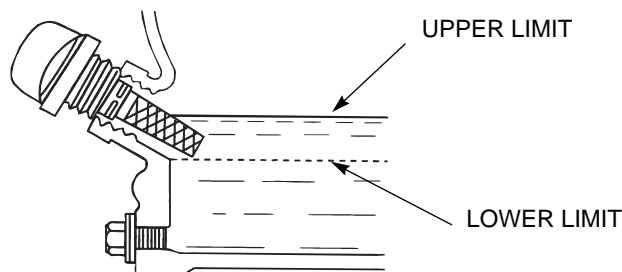

3. If the oil level is low, fill to the edge of the oil filler hole with the recommended oil.
4. Screw in the filler cap/dipstick securely.

NOTICE

Running the engine with a low oil level can cause engine damage.

Oil Change

Drain the oil while the engine is warm. Warm oil drains quickly and completely.

1. Remove the oil filler cap, drain plug, and sealing washer. Drain the oil into a suitable container.
2. Reinstall the drain plug and sealing washer. Tighten the plug securely.

Please dispose of used motor oil and the oil containers in a manner that is compatible with the environment. We suggest you take used oil in a sealed container to your local recycling center or service station for reclamation. Do not throw it in the trash or pour it on the ground or pour it down a drain.

3. Fill with the recommended oil to the top of the oil filler neck.
4. Screw in the oil filler cap securely.

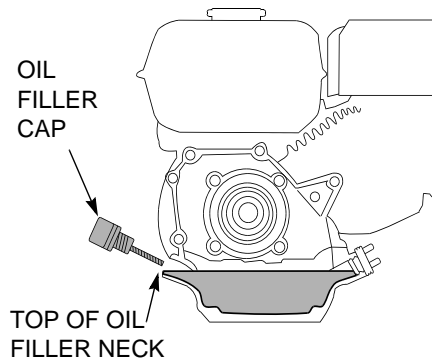
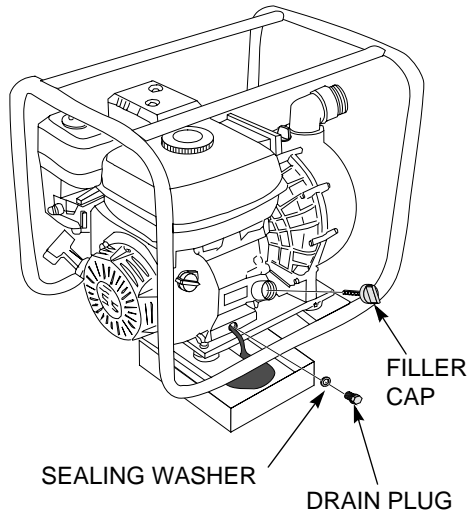

AIR CLEANER

Inspection

1. Unscrew the outer wing nut and remove the air cleaner cover.

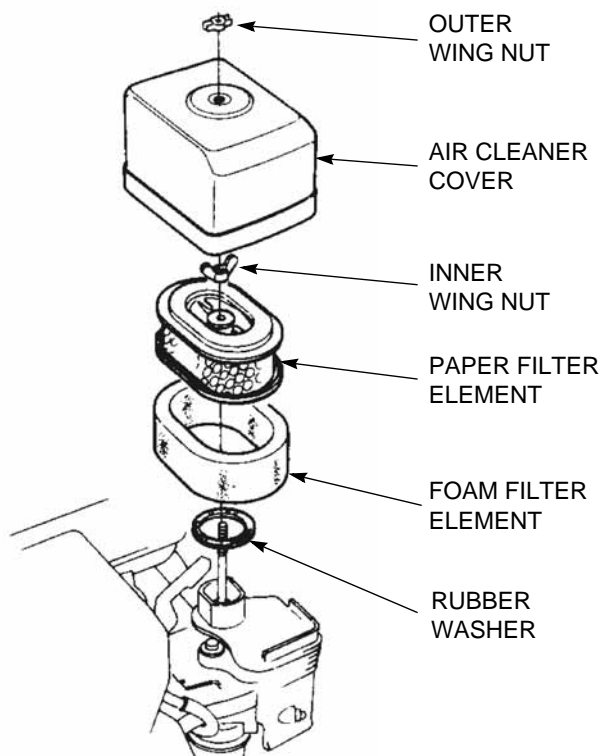

2. Remove the inner wing nut and both air filter elements.
3. Separate the air filter elements and carefully check them for holes or tears. Replace the filter elements if they are damaged.
4. If the air filter elements are dirty, clean them as described below.
5. Wipe dirt from the inside of the air cleaner housing and cover. Be careful to prevent dirt from entering the air duct that leads to the carburetor.
6. Install the foam element over the paper element, and install the assembled air filter. Secure the air filter with the inner wing nut. Make sure the rubber washer is in place under the filter elements.
7. Install the air cleaner cover, and secure with the outer wing nut.

NOTICE

Operating the engine without an air filter, or with a damaged air filter, will allow dirt to enter the engine, causing rapid engine wear. This type of damage is not covered by the DISTRIBUTOR'S LIMITED WARRANTY.

Cleaning

A dirty air filter will restrict air flow to the carburetor, reducing engine performance. If you operate the pump in very dusty areas, clean the air filter more often than specified in the *MAINTENANCE SCHEDULE* (page 7).

1. To clean the paper filter element, tap the element lightly several times on a hard surface to remove excess dirt, or blow compressed air [not exceeding 30 psi (207 kPa)] through the filter element from the inside out.

Never try to brush the dirt off; brushing will force dirt into the paper fibers. Replace the paper element if it is excessively dirty or damaged.

2. To clean the foam filter element, wash the element in a solution of household detergent and warm water, then rinse thoroughly, or wash in nonflammable solvent.

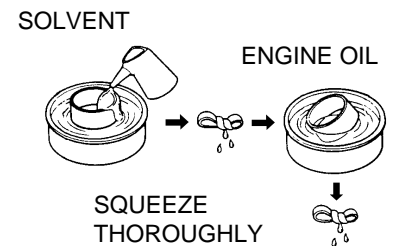

3. Allow the foam filter element to dry thoroughly.
4. Soak the foam filter element in clean engine oil and squeeze out the excess oil.

NOTICE

Excess oil will restrict air flow through the foam filter element and may transfer to the paper filter element, soaking and clogging it.

5. Reassemble the air filter in the reverse order of removal.

SPARK PLUG

Recommended Spark Plug: NGK - BPR6ES

NOTICE

Incorrect spark plugs can cause engine damage.

For good performance, the spark plug must be properly gapped and free of deposits.

Allow the engine to cool before servicing the spark plug.

1. Disconnect the spark plug cap and remove any dirt from around the spark plug area.
2. Use a spark plug wrench to remove the spark plug.
3. Visually inspect the spark plug. Discard it if the insulator is cracked, chipped, or fouled.

SPARK PLUG WRENCH

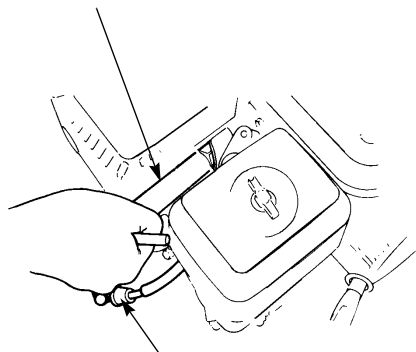

SPARK PLUG CAP

4. Measure the plug gap with a suitable gauge.

Correct as necessary by carefully bending the side electrode.

Plug gap:

**0.028 ~ 0.031 in
(0.7 ~ 0.8 mm)**

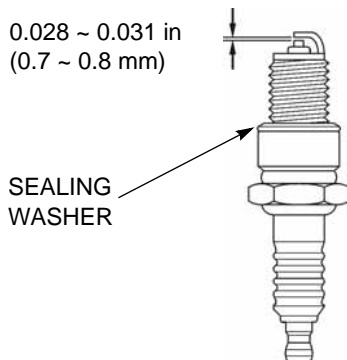

SEALING WASHER

5. Check that the spark plug washer is in good condition, and thread the spark plug in by hand to prevent cross-threading.

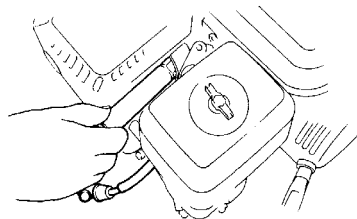

6. After the spark plug is seated, tighten with a spark plug wrench to compress the washer.

If installing a new spark plug, tighten 1/2 turn after the spark plug seats to compress the washer.

If reinstalling a used spark plug, tighten 1/8 - 1/4 turn after the spark plug seats to compress the washer.

NOTICE

A loose spark plug can overheat and damage the engine. Overtightening the spark plug can damage the threads in the cylinder head.

7. Reconnect the spark plug cap.

SPARK ARRESTER (OPTIONAL EQUIPMENT)

Your pump engine is not factory-equipped with a spark arrester. In some areas, it is illegal to operate an engine without a spark arrester. Check local laws and regulations. An optional USDA approved spark arrester is available from an authorized Honda servicing dealer. See page 16 for part numbers.

The spark arrester must be serviced every 100 hours to keep it functioning as designed.

1. Allow the engine to cool, remove the two 8 mm nuts, and remove the muffler from the cylinder head.
2. Remove the four 5 mm screws from the muffler protector and remove the muffler protector.
3. Remove the 4 mm screw from the spark arrester and remove the spark arrester from the muffler.

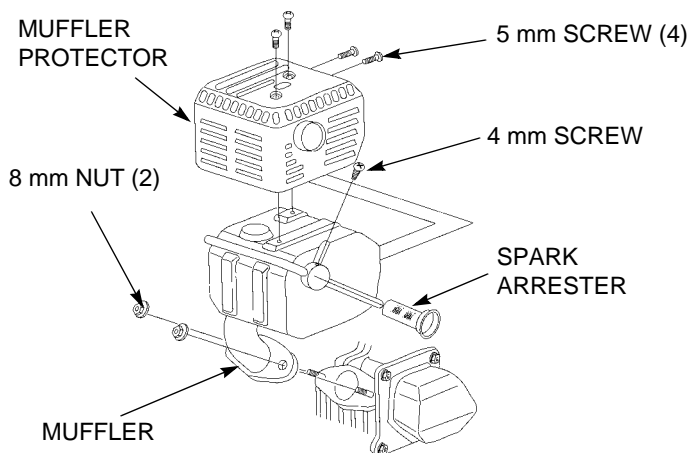

4. Use a stiff brush to remove carbon deposits from the spark arrester screen. Be careful not to damage the spark arrester screen.
5. Inspect the spark arrester for breaks and holes. Replace it if necessary.
6. Install the spark arrester and the muffler in the reverse order of disassembly.

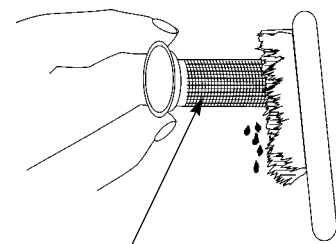

SPARK ARRESTER SCREEN

Sediment Cup Cleaning

1. Turn the fuel valve to the OFF position.
2. Remove the sediment cup and O-ring and wash them in nonflammable solvent. Dry them thoroughly.
3. Install the O-ring and sediment cup and tighten securely.
4. Turn the fuel valve to the ON position and check for leaks.

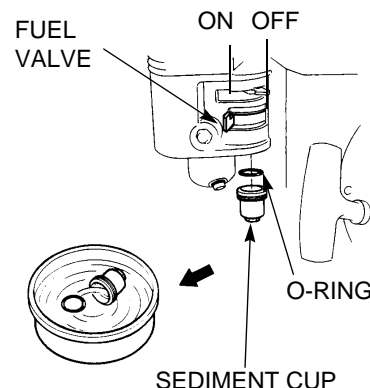

TRANSPORTING

BEFORE LOADING

When transporting the pump, be sure to keep it upright. If the pump is tilted or overturned, fuel may spill from the tank, which can result in a fire hazard.

Allow the engine to cool before transporting the pump.

1. Turn the ignition switch to the OFF position.

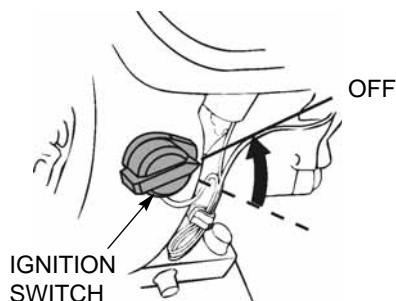

2. Turn the fuel valve to the OFF position.

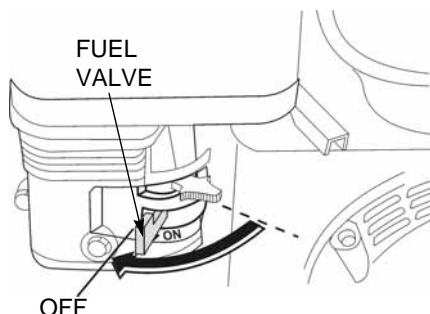

3. Drain the pump chamber into a suitable container. Follow the chemical manufacturer's handling procedures.
4. Dispose of the liquid or chemical properly and reinstall the drain plug.

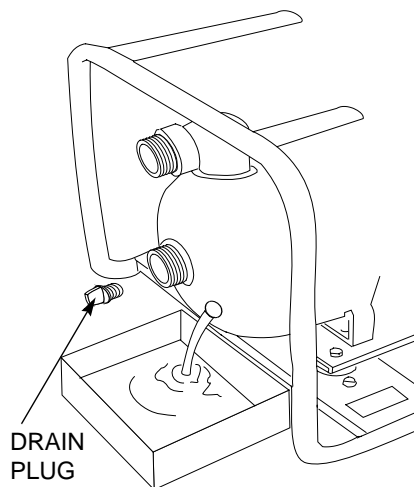

LOADING AND UNLOADING

Position the pump so that it is level on the transport vehicle. Tie the pump down with rope or straps attached to the frame. Keep the tie-down rope or straps away from the controls and carburetor.

STORAGE

STORAGE PREPARATION

Proper storage preparation is essential for keeping your pump trouble-free and looking good. The following steps will help to keep rust and corrosion from impairing your pump's function and appearance, and will make the engine easier to start when you use the pump again.

Cleaning the Engine

Wash the engine by hand, and be careful to prevent water from entering the air cleaner or muffler.

NOTICE

- Using a garden hose or pressure washing equipment can force water into the air cleaner. Water in the air cleaner will soak the filter and can enter the carburetor or engine, causing damage.
- Water contacting a hot engine can cause damage. If the engine has been running, allow it to cool for at least half an hour before washing.

Cleaning the Pump

1. Wash the pump with a garden hose or other low pressure equipment. Keep water away from controls and all other places that are difficult to dry, as water may promote rust.
2. After washing, remove as much standing water as possible with a dry cloth. Fill the pump chamber with water. Start the engine outdoors and let it run until it reaches normal operating temperature to evaporate any water remaining on the engine.

NOTICE

Operating the pump dry will damage the pump seal. Be sure the pump chamber is filled with water before starting the engine.

3. Stop the engine and allow it to cool.
4. If the pump was filled with a chemical, follow the chemical manufacturer's handling procedures.

Clean the pump interior by removing the pump drain plug and flushing with fresh water. After flushing, drain the water from the pump chamber. Install the pump drain plug.

5. After the pump is clean and dry, touch up any damaged paint, and coat other areas that may rust with a light film of oil.

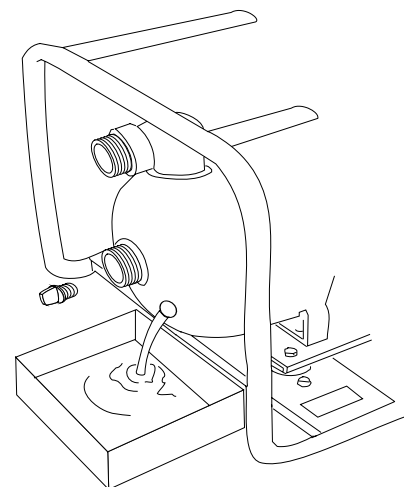

Fuel

NOTICE

Depending on the region where you operate your equipment, fuel formulations may deteriorate and oxidize rapidly. Fuel deterioration and oxidation can occur in as little as 30 days and may cause damage to the carburetor and/or fuel system. Please check with your servicing dealer for local storage recommendations.

Gasoline will oxidize and deteriorate in storage. Old gasoline will cause hard starting, and it leaves gum deposits that clog the fuel system. If the gasoline in your pump's engine deteriorates during storage, you may need to have the carburetor and other fuel system components serviced or replaced.

The length of time that gasoline can be left in your fuel tank and carburetor without causing functional problems will vary with such factors as gasoline blend, your storage temperatures, and whether the fuel tank is partially or completely filled. The air in a partially filled fuel tank promotes fuel deterioration. Very warm storage temperatures accelerate fuel deterioration. Fuel deterioration problems may occur within a few months, or even less if the gasoline was not fresh when you filled the fuel tank.

The *DISTRIBUTOR'S LIMITED WARRANTY* does not cover fuel system damage or engine performance problems resulting from neglected storage preparation.

You can extend fuel storage life by adding a fuel stabilizer that is formulated for that purpose, or you can avoid fuel deterioration problems by draining the fuel tank and carburetor.

Adding Fuel Stabilizer to Extend Fuel Storage Life

Fill the fuel tank with fresh gasoline. If only partially filled, air in the tank will promote fuel deterioration during storage. If you keep a container of gasoline for refueling, be sure that it contains only fresh gasoline.

1. Add fuel stabilizer following the manufacturer's instructions.
2. After adding a fuel stabilizer, run the engine outdoors for 10 minutes to be sure that treated gasoline has replaced the untreated gasoline in the carburetor.

NOTICE

Operating the pump dry will damage the pump seal. Be sure the pump chamber is filled with water before starting the engine.

3. Stop the engine and turn the fuel valve to the OFF position (page 6). Drain the pump chamber.

Draining the Fuel Tank and Carburetor

1. Make sure the fuel valve is OFF.
2. Remove the carburetor drain screw with a 10 mm wrench or screwdriver, and drain the fuel into an approved gasoline container.

⚠ WARNING

Gasoline is highly flammable and explosive.

You can be burned or seriously injured when handling fuel.

- Stop the engine and keep heat, sparks, and flame away.
- Handle fuel only outdoors.
- Wipe up spills immediately.

3. Turn the fuel valve to the ON position. This will allow fuel in the fuel tank to drain through the carburetor bowl.

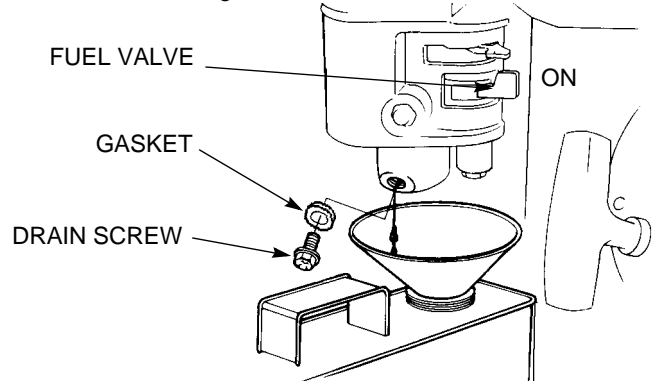

4. Reinstall the drain screw and gasket.

Engine Oil

Change the engine oil (page 9).

Engine Cylinder

1. Remove the spark plug (page 10).
2. Pour a tablespoon (5 ~ 10 cc) of clean engine oil into the cylinder.
3. Slowly pull the starter grip a few times to distribute the oil in the cylinder.
4. Reinstall the spark plug.
5. Pull the starter grip slowly until resistance is felt. Continue pulling slowly until the arrow notch on the starter pulley aligns with the hole on the recoil starter. Return the starter grip gently. This will close the valves so moisture cannot enter the engine cylinder.

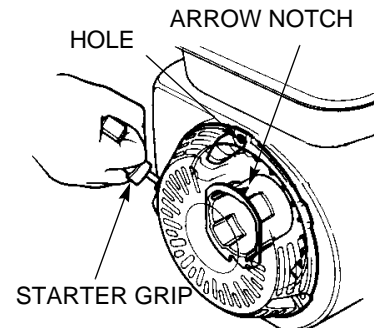

PLACING IN STORAGE

If your pump will be stored with gasoline in the fuel tank and carburetor, it is important to reduce the hazard of gasoline vapor ignition. Select a well-ventilated storage area away from any appliance that operates with a flame, such as a furnace, water heater, or clothes dryer. Also avoid any area with a spark producing electric motor, or where power tools are operated.

If possible, avoid storage areas with high humidity, because that promotes rust and corrosion.

Unless all fuel has been drained from the fuel tank, leave the fuel valve in the OFF position to reduce the possibility of fuel leakage.

Place the pump on a level surface. Tilting can cause fuel or oil leakage.

With the engine and exhaust system cool, cover the pump to keep out dust. A hot engine and exhaust system can ignite or melt some materials.

Do not use sheet plastic as a dust cover. A nonporous cover will trap moisture around the pump, promoting rust and corrosion.

REMOVAL FROM STORAGE

Check your pump as described in *BEFORE OPERATION* (page 3).

If the fuel was drained during storage preparation, fill the tank with fresh gasoline. If you keep a container of gasoline for refueling, be sure that it contains only fresh gasoline. Gasoline oxidizes and deteriorates over time, causing hard starting.

If the cylinder was coated with oil during storage preparation, the engine may smoke briefly at startup. This is normal.

TAKING CARE OF UNEXPECTED PROBLEMS

Engine Will Not Start

Possible Cause	Correction
Ignition switch OFF	Turn the ignition switch ON (page 6).
Fuel valve OFF	Turn the fuel valve ON (page 6).
Out of fuel	Refuel (page 8).
Oil level low	Add oil (page 8)
Bad fuel; pump stored without treating or draining gasoline, or refueled with bad gasoline	Drain the fuel tank and carburetor (page 12). Refuel with fresh gasoline (page 8).
Spark plug faulty, fouled, or improperly gapped	Gap or replace the spark plug (page 10).
Spark plug wet with fuel (flooded engine)	Dry and reinstall the spark plug.
Fuel filter clogged, carburetor malfunction, ignition malfunction, valves stuck, etc.	Take the pump to an authorized Honda servicing dealer for repair.

Loss of Power

Possible Cause	Correction
Throttle not set to FAST	Move the throttle to the FAST position.
Air filter clogged	Clean or replace the air filter (page 9).
Bad fuel; pump stored without treating or draining gasoline, or refueled with bad gasoline	Drain the fuel tank and carburetor. (page 12) Refuel with fresh gasoline.
Fuel filter clogged, carburetor malfunction, ignition malfunction, valves stuck, etc.	Take the pump to an authorized Honda service dealer for repair.

Pump Will Not Pump

Possible Cause	Correction
Strainer clogged	Clear strainer (page 4).
Suction hose clamps loose	Tighten hose clamps (page 4).
Suction hose sealing washer not installed	Install suction hose sealing washer (page 4).
Suction head is too high	Locate pump at appropriate level (page 15).
Pump requires priming	Prime the pump (page 4).
Pump still does not pump	Take the pump to an authorized Honda servicing dealer for repair.

TECHNICAL INFORMATION

SERIAL NUMBER LOCATIONS

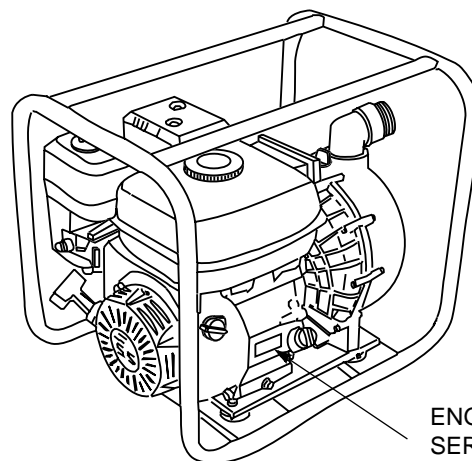

ENGINE SERIAL NUMBER

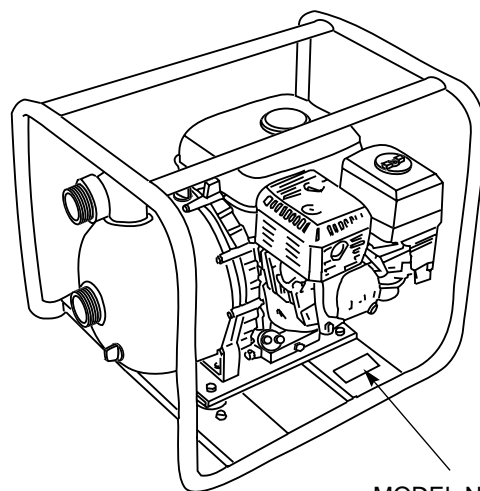

MODEL NAME AND FRAME SERIAL NUMBER

There are two serial numbers, one for the engine and one for the frame. Record the engine and frame serial numbers and date of purchase in the space below. You will need these serial numbers when ordering parts and when making technical or warranty inquiries.

Engine serial number: _____

Frame serial number: _____

Date of purchase: _____

CARBURETOR MODIFICATION FOR HIGH ALTITUDE OPERATION

At high altitude, the standard carburetor air-fuel mixture will be too rich. Performance will decrease, and fuel consumption will increase. A very rich mixture will also foul the spark plug and cause hard starting. Operation at an altitude that differs from that at which this engine was certified, for extended periods of time, may increase emissions.

High altitude performance can be improved by specific modifications to the carburetor. If you always operate your pump at altitudes above 5,000 feet (1,500 meters), have your servicing dealer perform this carburetor modification. This engine, when operated at high altitude with the carburetor modifications for high altitude use, will meet each emission standard throughout its useful life.

Even with carburetor modification, engine horsepower will decrease about 3.5% for each 1,000-foot (300-meter) increase in altitude. The effect of altitude on horsepower will be greater than this if no carburetor modification is made.

NOTICE

When the carburetor has been modified for high altitude operation, the air-fuel mixture will be too lean for low altitude use. Operation at altitudes below 5,000 feet (1,500 meters) with a modified carburetor may cause the engine to overheat and result in serious engine damage. For use at low altitudes, have your servicing dealer return the carburetor to original factory specifications.

EMISSION CONTROL SYSTEM

Source of Emissions

The combustion process produces carbon monoxide, oxides of nitrogen, and hydrocarbons. Control of hydrocarbons and oxides of nitrogen is very important because, under certain conditions, they react to form photochemical smog when subjected to sunlight. Carbon monoxide does not react in the same way, but it is toxic.

Honda utilizes appropriate air/fuel ratios and other emissions control systems to reduce the emissions of carbon monoxide, oxides of nitrogen, and hydrocarbons.

The U.S., California Clean Air Act, and Environment Canada

EPA, California, and Canadian regulations require all manufacturers to furnish written instructions describing the operation and maintenance of emissions control systems.

The following instructions and procedures must be followed in order to keep the emissions from your Honda engine within the emissions standards.

Tampering and Altering

Tampering with or altering the emissions control system may increase emissions beyond the legal limit. Among those acts that constitute tampering are:

- Removal or alteration of any part of the intake, fuel, or exhaust systems.
- Altering or defeating the speed-adjusting mechanism to cause the engine to operate outside its design parameters.

Problems That May Affect Emissions

If you are aware of any of the following symptoms, have your engine inspected and repaired by your servicing dealer.

- Hard starting or stalling after starting
- Rough idle
- Misfiring or backfiring under load
- Afterburning (backfiring)
- Black exhaust smoke or high fuel consumption

Replacement Parts

The emissions control systems on your new Honda engine were designed, built, and certified to conform with EPA, California, and Canadian emissions regulations. We recommend the use of Honda Genuine parts whenever you have maintenance done. These original-design replacement parts are manufactured to the same standards as the original parts, so you can be confident of their performance. The use of replacement parts that are not of the original design and quality may impair the effectiveness of your emissions control system.

A manufacturer of an aftermarket part assumes the responsibility that the part will not adversely affect emissions performance. The manufacturer or rebuilder of the part must certify that use of the part will not result in a failure of the engine to comply with emissions regulations.

Maintenance

Follow the *MAINTENANCE SCHEDULE* on page 7. Remember this schedule is based on the assumption that your machine will be used for its designed purpose. Sustained high-load or high-temperature operation, or use in unusually wet or dusty conditions, will require more frequent service.

AIR INDEX

An Air Index Information hang tag/label is applied to engines certified to an emission durability time period in accordance with the requirements of the California Air Resources Board.

The bar graph is intended to provide you, our customer, the ability to compare the emissions performance of available engines. The lower the Air Index, the less pollution.

The durability description is intended to provide you with information relating to the engine's emission durability period. The descriptive term indicates the useful life period for the engine's emission control system. See your *EMISSION CONTROL SYSTEM WARRANTY* (page 18) for additional information.

Descriptive Term	Applicable to Emission Durability Period
Moderate	50 hours (0–80 cc inclusive) 125 hours (greater than 80 cc)
Intermediate	125 hours (0–80 cc inclusive) 250 hours (greater than 80 cc)
Extended	300 hours (0–80 cc inclusive) 500 hours (greater than 80 cc) 1000 hours (225 cc and greater)

SPECIFICATIONS

Dimensions and Weight

Model	WMP20X
Description code	WAAA
Length x Width x Height	20.5 x 15.7 x 17.7 in (520 x 400 x 450 mm)
Dry weight	56.2 lbs (25.5 kg)

Engine Design and Performance

Model	GX160K1
Engine type	4-stroke, overhead-valve, single cylinder
Displacement [bore x stroke]	9.9 cu in (163 cc) [2.7 x 1.8 in (68 x 45 mm)]
Oil capacity	0.6 qt (0.6 ℓ)
Fuel capacity	0.82 US gal (3.1 ℓ)
Cooling system	Forced air
Ignition system	Transistorized magneto
PTO shaft direction	Counterclockwise

Pump

Pump type	Suction
Suction port diameter	2 in (50.8 mm)
Discharge port diameter	
Rated rpm (max load)	3500 rpm
Total head (max)	105 ft (32 m)
Suction head (max)	26 ft (8 m)
Discharge capacity (max)	220 gpm (833 ℓ/min)
Self-priming time	65 sec at 16.4 ft (5 m)
Pressure (max)	45 psi (310 kPa)
Continuous running time*	2 hrs, 15 min

* Approximate time. Actual time will depend on pump load.

Maintenance

Fuel	Unleaded gasoline with a pump octane rating of 86 or higher	See page 8
Engine oil	SAE 10W-30 API SJ or later	See page 8
Spark plug type	NGK- BPR6ES	See page 10
Maximum governed speed	3,700 ~ 4,000 rpm	Shop manual

Tune-up

Spark plug gap	0.028 ~ 0.031 in (0.7 ~ 0.8 mm)	See page 10
Carburetor idle speed	1,400 ⁺²⁰⁰ ₋₁₅₀ rpm	Shop manual
Valve clearance (cold)	Intake: 0.15 ± 0.02 mm Exhaust: 0.20 ± 0.02 mm	See your authorized Honda servicing dealer
Other specifications	No other adjustments needed	

Pump Performance Curve

This graph shows the relationship between the pump discharge capacity and the total dynamic head, based on clear water at sea level. As you increase the total head, the discharge capacity will decrease.

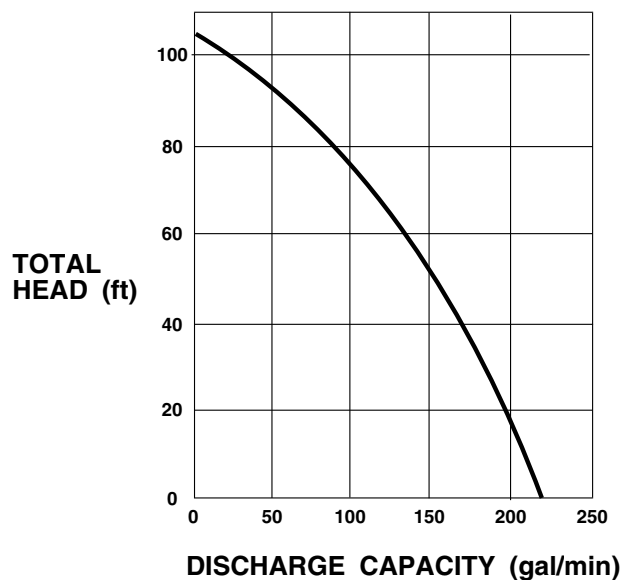

CONSUMER INFORMATION

REPLACEMENT PARTS, OPTIONAL EQUIPMENT, AND SERVICE ITEMS

Contact an authorized Honda servicing dealer to purchase any of these (or other) Honda Genuine items for your pump.

Replacement Parts

Item	Part Number	Notes
Spark plug	98079-56846	NGK (brand) BPR6ES
Air filter	17210-ZE1-517	Includes paper and foam elements
Strainer	78325-YE0-003	Clamp not included

Optional Equipment

Item	Part Number	Notes
Spark arrester	18310-ZH8-810	Muffler
	18355-ZE1-000	Arrester
	90055-ZE1-000	Screw
Pin lug hose kit (2 in.)	124020-1145-PINKT	Each kit includes: 20' suction hose, 50' discharge hose, Steel strainer (3/8" hole)
Camlock hose kit (2 in.)	124020-1145-CLKT	
No-Spill gas can	06176-1450	5 gal

Service Items

Item	Part Number	Notes
SAE 10W-30 engine oil	08207-10W30	Honda Genuine recommended oil
Fuel stabilizer	08732-0001	For storage 8 oz. bottle

DEALER LOCATOR INFORMATION

To find an Authorized Honda Servicing Dealer anywhere in the United States:

Visit www.HondaPowerEquipment.com and click on Dealer Locator.

CUSTOMER SERVICE INFORMATION

Honda Power Equipment dealership personnel are trained professionals. They should be able to answer any question you may have. If you encounter a problem that your dealer does not solve to your satisfaction, please discuss it with the dealership's management. The Service Manager or General Manager can help. Almost all problems are solved in this way.

If you are dissatisfied with the decision made by the dealership's management, contact the Honda Power Equipment Customer Relations Office. You can write:

American Honda Motor Co., Inc.

Power Equipment Division
Customer Relations Office
4900 Marconi Drive
Alpharetta, GA 30005-8847

Or telephone: (770) 497-6400 M-F, 8:30 a.m. - 7:00 p.m. ET

When you write or call, please give us this information:

- Model and serial numbers (page 13)
- Name of the dealer who sold the pump to you
- Name and address of the dealer who services your pump
- Date of purchase
- Your name, address, and telephone number
- A detailed description of the problem

Honda Publications

These publications will give you additional information for maintaining and repairing your pump.

Shop Manual - This manual covers complete maintenance and overhaul procedures. It is intended to be used by a skilled technician. Available through your Honda dealer or through Helm Inc. at (888) 292-5395 or visit www.HondaPowerEquipment.com and click on Product Manuals

Parts Catalog - This manual provides complete, illustrated parts lists, and is available through your Honda dealer.

Accessories Catalog

Your authorized Honda power equipment dealer offers a wide selection of accessories to make your pump even more useful. Visit www.HondaPowerEquipment.com and click on Accessories and then Pumps to see the entire catalog of accessories.

Especially popular accessories include:

- Suction and discharge hoses
- Strainers
- Couplers and gaskets

Frequently Asked Questions - The Honda Power Equipment web site provides additional information for users of Honda power equipment. Visit www.HondaPowerEquipment.com and click on FAQs.

DISTRIBUTOR'S LIMITED WARRANTY

Honda Power Equipment

This warranty is limited to the following Honda Power Equipment products when distributed by American Honda Motor Co., Inc., Power Equipment Division, 4900 Marconi Drive, Alpharetta, Georgia 30005-8847. The following warranty applies to products purchased at retail or placed in rental service on or after January 1, 2010.

PRODUCTS COVERED BY THIS WARRANTY	LENGTH OF WARRANTY (from date of original retail purchase)	
	PRIVATE RESIDENTIAL ⁽¹⁾	COMMERCIAL/ RENTAL/INSTITUTIONAL
WMP20X pump	36 months	36 months

⁽¹⁾ Private residential: Used in maintaining owner's primary and/or secondary residence. Any other use, including but not limited to informal "for hire" use, is considered commercial/rental/institutional use.

To Qualify for This Warranty:

The product must be purchased in the United States, Puerto Rico, or the U.S. Virgin Islands from American Honda or a dealer authorized by American Honda to sell those products. This warranty applies to the first retail purchaser and each subsequent owner during the applicable warranty time period.

What American Honda Will Repair or Replace Under Warranty:

American Honda will repair or replace, at its option, any part that is proven to be defective in material or workmanship under normal use during the applicable warranty time period. Warranty repairs and replacements will be made without charge for parts or labor. Anything replaced under warranty becomes the property of American Honda Motor Company, Inc. All parts replaced under warranty will be considered as part of the original product, and any warranty on those parts will expire coincident with the original product warranty.

To Obtain Warranty Service:

You must, at your expense, take the Honda Power Equipment product, accessory, replacement part, apparel, or the power equipment on which the accessory or replacement part is installed, and proof of purchase to any Honda Power Equipment dealer in the United States, Puerto Rico, or the U.S. Virgin Islands who is authorized to sell that product, during the dealer's normal business hours. If you are unable to obtain warranty service or are dissatisfied with the warranty service you receive, take the following steps: First, contact the owner of the dealership involved; normally this will resolve the problem. However, if you should require further assistance, write or call the Power Equipment Customer Relations Dept. of American Honda Motor Co., Inc. at the following address:

American Honda Motor Co., Inc.
Power Equipment Customer Relations Dept.
4900 Marconi Drive
Alpharetta, GA 30005-8847 Telephone: (770) 497-6400

Exclusions:

- Any damage or deterioration resulting from the following:
 - Neglect of the periodic maintenance as specified in this manual
 - Improper repair or maintenance
 - Operating methods other than those indicated in this manual
 - The use of non-genuine Honda parts and accessories other than those approved by Honda (other than recommended lubricants and fluids)
 - Exposure of the product to soot and smoke, chemical agents, bird droppings, sea water, sea breeze, salt or other environmental phenomena
 - Collision, fuel contamination or deterioration, neglect, unauthorized alteration, misuse, incorporation or use of unsuitable attachments or parts
 - Natural wear and tear (natural fading of painted or plated surfaces, sheet peeling and other natural deterioration)
- Consumable parts: Honda does not warrant parts deterioration due to natural wear and tear. The parts listed below are not covered by warranty (unless they are needed as a part of another warranted repair):
 - Spark plug, fuel filter, air cleaner element, clutch disc, tire, wheel bearing, recoil starter rope, cable, belt, cutter blade.
 - Lubricant: oil and grease.
- Cleaning, adjustment, and normal periodic maintenance work (carburetor cleaning, engine oil draining, blade sharpening, belt and cable adjustments).
- Any product that has ever been declared a total loss or sold for salvage by a financial institution or insurer.
- Auger and paddle assemblies of snowthrowers, tiller tines of roto-tillers, mower blades and mower deck housings, are specifically not warranted against impact damage, including but not limited to, abrasive damage.

Disclaimer of Consequential Damage and Limitation of Implied Warranties:

American Honda disclaims any responsibility for loss of time or use of the product, transportation, commercial loss, or any other incidental or consequential damage. Any implied warranties are limited to the duration of this written limited warranty. Some states do not allow limitations on how long an implied warranty lasts and/or do not allow the exclusion or limitation of incidental or consequential damages, so the above exclusions and limitations may not apply to you. This warranty gives you specific legal rights, and you may also have other rights which vary from state to state.

Honda Accessories, Replacement Parts, And Apparel

This warranty is limited to Honda Power Equipment parts, accessories, and apparel when distributed by American Honda Motor Co., Inc., 4900 Marconi Drive, Alpharetta, Georgia 30005-8847.

PRODUCTS COVERED BY THIS WARRANTY	LENGTH OF WARRANTY (from date of original retail purchase)	
	PRIVATE RESIDENTIAL	COMMERCIAL/ RENTAL/INSTITUTIONAL
Accessories	12 months	3 months
Replacement parts	6 months	3 months
Apparel	6 months	3 months

To Qualify for This Warranty:

- The accessories, replacement parts, or apparel must be purchased from American Honda, or a dealer, distributor, or distributor's dealer authorized by American Honda to sell those products in the United States, Puerto Rico, and the U.S. Virgin Islands. Parts and Accessories must be purchased for installation on original Honda equipment or engines to be eligible for warranty coverage. Installing parts and accessories on non-Honda products or engines voids this warranty.
- You must be the first retail purchaser. This warranty is not transferable to subsequent owners.

What American Honda Will Repair or Replace Under Warranty:

American Honda will repair or replace, at its option, any Honda Power Equipment accessories, replacement parts, or apparel that are proven to be defective in material or workmanship under normal use during the applicable warranty time period. Anything replaced under warranty becomes the property of American Honda Motor Company, Inc. All parts replaced under warranty will be considered as part of the original product, and any warranty on those parts will expire coincident with the original product warranty.

Accessories and replacement parts installed by a dealer, distributor, or distributor's dealer who is authorized by American Honda to sell them will be repaired or replaced under warranty without charge for parts or labor. If installed by anyone else, accessories and replacement parts will be repaired or replaced under warranty without charge for parts, but any labor charges will be the responsibility of the purchaser. Apparel will be repaired or replaced under warranty without any charge.

To Obtain Warranty Service:

You must, at your expense, take the Honda Power Equipment accessory, replacement part, apparel, or the Honda Power Equipment on which the accessory or replacement part is installed, and proof of purchase to any Honda Power Equipment dealer, distributor, or distributor's dealer in the United States, Puerto Rico, or the U.S. Virgin Islands who is authorized to sell that product, during the dealer's or distributor's normal business hours. If you are unable to obtain warranty service or are dissatisfied with the warranty service you receive, take the following steps: First, contact the owner of the dealership or distributorship involved; normally this will resolve the problem. However, if you should require further assistance, write or call the Power Equipment Customer Relations Department of American Honda Motor Co., Inc. Refer to adjacent column for contact information.

Exclusions:

This warranty does not extend to accessories, parts, or apparel affected or damaged by collision, normal wear, use in an application for which the product was not designed or any other misuse, neglect, incorporation or use of unsuitable attachments or parts, unauthorized alteration, improper installation, or any causes other than defects in material or workmanship of the product. Installing Parts and Accessories on non-Honda products or engines voids this warranty.

Disclaimer of Consequential Damage and Limitation of Implied Warranties:

American Honda disclaims any responsibility for loss of time or use of the product, or the power equipment on which the product is installed, transportation, commercial loss, or any other incidental or consequential damage. Any implied warranties are limited to the duration of this written warranty. Some states do not allow limitations on how long an implied warranty lasts and/or do not allow the exclusion or limitation of incidental or consequential damages, so the above exclusions and limitations may not apply to you. This warranty gives you specific legal rights, and you may also have other rights which vary from state to state.

EMISSION CONTROL SYSTEM WARRANTY

Your new Honda Power Equipment engine complies with the U.S. EPA, Environment Canada, and State of California emission regulations (models certified for sale in California only). American Honda Motor Co., Inc. provides the emission warranty coverage for engines in the United States and its territories. Honda Canada Inc. provides the emission warranty for engines in the 13 provinces and territories of Canada. In the remainder of this Emission Control System Warranty, American Honda Motor Company Inc. and Honda Canada Inc. will be referred to as Honda.

YOUR WARRANTY RIGHTS AND OBLIGATIONS:

CALIFORNIA

The California Air Resources Board and Honda are pleased to explain the emission control system warranty on your Honda Power Equipment engine. In California, new spark-ignited small off-road equipment engines must be designed, built, and equipped to meet the State's stringent anti-smog standards.

OTHER STATES, U.S. TERRITORIES, AND CANADA

In other areas of the United States and in Canada, your engine must be designed, built, and equipped to meet the U.S. EPA and Environment Canada emission standards for spark-ignited engines at or below 19 kilowatts. Specific Honda products that do not meet the California emissions regulations can be identified by a "Not for sale in California" decal.

ALL OF THE UNITED STATES AND CANADA

Honda must warrant the emission control system on your power equipment engine for the period of time listed below, provided there has been no abuse, neglect, or improper maintenance of your power equipment engine. Where a warrantable condition exists, Honda will repair your power equipment engine at no cost to you including diagnosis, parts, and labor.

Your emission control system may include such parts as the carburetor or fuel injection system, the ignition system, and catalytic converter. Also included may be hoses, connectors, and other emission-related assemblies. (See adjacent table for additional covered parts).

OWNER'S WARRANTY RESPONSIBILITY:

As the power equipment engine owner, you are responsible for the performance of the required maintenance listed in your owner's manual. Honda recommends that you retain all receipts covering maintenance on your power equipment engine, but Honda cannot deny warranty coverage solely for the lack of receipts or for your failure to ensure the performance of all scheduled maintenance.

As the power equipment engine owner, you should however be aware Honda may deny you warranty coverage if your power equipment engine or a part has failed due to abuse, neglect, improper maintenance, or unapproved modifications.

You are responsible for presenting your power equipment engine to a Honda Power Equipment dealer as soon as a problem exists. The warranty repairs should be completed in a reasonable amount of time, not to exceed 30 days. If you have any questions regarding your emissions warranty rights and responsibilities, you should contact the Honda Office in your region:

American Honda Motor Co., Inc. Power Equipment Customer Relations 4900 Marconi Drive Alpharetta, Georgia 30005-8847 Telephone: (888) 888-3139 Email: powerequipmentemissions @ahm.honda.com	or	Honda Canada Inc. Power Equipment Customer Relations Please visit: www.honda.ca for contact information. Telephone: (888) 946-6329
--	----	---

WARRANTY COVERAGE:

Honda power equipment engines sold in the United States and Canada are covered by this warranty for a period of two years from the date of delivery to the original retail purchaser or the length of the Honda Distributor's Limited Warranty, whichever is longer. This warranty is transferable to each subsequent purchaser for the duration of the warranty period.

If any emission-related part on your engine is defective, the part will be repaired or replaced by Honda without charge for diagnosis, parts, or labor. All defective parts replaced under this warranty become the property of Honda. A list of warranted parts is in the adjacent column. Normal maintenance items, such as spark plugs and filters, that are on the warranted parts list are warranted up to their required replacement interval only.

Honda will also replace other engine components damaged by a failure of any warranted part during the warranty period.

Only Honda approved replacement parts may be used in the performance of any warranty repairs and must be provided without charge to the owner. The use of replacement parts not equivalent to the original parts may impair the effectiveness of your engine emission control system. If such a replacement part is used in the repair or maintenance of your engine, and an authorized Honda dealer determines it is defective or causes a failure of a warranted part, your claim for repair of your engine may be denied. If the part in question is not related to the reason your engine requires repair, your claim will not be denied.

TO OBTAIN WARRANTY SERVICE:

You must, at your own expense, take your Honda Power Equipment engine or the product on which it is installed, along with your sales registration card or other proof of original purchase date, to any Honda Power Equipment dealer who is authorized by Honda to sell and service that Honda product during his normal business hours. Claims for repair or adjustment found to be caused solely by defects in material or workmanship will not be denied because the engine was not properly maintained and used.

If you are unable to obtain emission warranty service or are dissatisfied with the warranty service you received, contact the owner of the dealership involved. Normally this should resolve your problem. However, if you require further assistance, contact the Honda office in your region. Refer to adjacent column for contact information.

EXCLUSIONS:

Failures other than those resulting from defects in material or workmanship are not covered by this warranty. This warranty does not extend to emission control systems or parts that are affected or damaged by owner abuse, neglect, improper maintenance, misuse, misfueling, improper storage, collision, the incorporation of, or use of, unsuitable attachments, or the unauthorized alteration of any part.

This warranty does not cover replacement of expendable maintenance items made in connection with required maintenance service after the item's first scheduled replacement as listed in the maintenance section of the product Owner's Manual, such as: spark plugs and filters.

DISCLAIMER OF CONSEQUENTIAL DAMAGE AND LIMITATION OF IMPLIED WARRANTIES:

American Honda Motor Co., Inc. and Honda Canada disclaim any responsibility for incidental or consequential damages such as loss of time or the use of the power equipment, or any commercial loss due to the failure of the equipment; and any implied warranties are limited to the duration of this written warranty. This warranty is applicable only where the California, U.S. EPA or Environment Canada emission control system warranty regulation is in effect.

EMISSION CONTROL SYSTEM WARRANTY PARTS:

SYSTEMS COVERED BY THIS WARRANTY:	PARTS DESCRIPTION:
Fuel Metering	Carburetor assembly, (includes starting enrichment system), Engine temperature sensor, Engine control module, Fuel regulator, Intake manifold
Evaporative	Fuel tank, Fuel cap, Fuel hoses, Vapor hoses, Carbon canister, Canister mounting brackets, Fuel strainer, Fuel cock, Fuel pump, Fuel hose joint, Canister purge hose joint
Exhaust	Catalyst, Exhaust manifold
Air Induction	Air filter housing, Air filter element*
Ignition	Flywheel magneto, Ignition pulse generator, Crankshaft position sensor, Power coil, Ignition coil assembly, Ignition control module, Spark plug cap, Spark plug*
Crankcase Emission Control	Crankcase breather tube, Oil filler cap
Miscellaneous Parts	Tubing, fittings, seals, gaskets, and clamps associated with these listed systems.

Note: This list applies to parts supplied by Honda and does not cover parts supplied by the equipment manufacturer. Please see the original equipment manufacturer's emissions warranty for non-Honda parts.

* Covered up to the first required replacement only. See the *MAINTENANCE SCHEDULE* on page 7.

NOTES

HONDA
The Power of Dreams