

Please read and save these instructions. Read carefully before attempting to assemble, install, operate or maintain the product described. Protect yourself and others by observing all safety information. Failure to comply with instructions could result in personal injury and/or property damage! Retain instructions for future reference.



# Engine Driven Centrifugal Pump



## Description

The Wayne pumps are general use centrifugal water pumps. The pump is equipped with a Viton® seal assembly that is also compatible with many agricultural chemicals.

## Safety Guidelines

This manual contains information that is very important to know and understand. This information is provided for SAFETY and to PREVENT EQUIPMENT PROBLEMS. To help recognize this information, observe the following symbols.

### ⚠ DANGER

**Danger indicates an imminently hazardous situation which, if not avoided, WILL result in death or serious injury.**

### ⚠ WARNING

**Warning indicates a potentially hazardous situation which, if not avoided, COULD result in death or serious injury.**

### ⚠ CAUTION

**Caution indicates a potentially minor or moderate injury.**

### NOTICE

**Notice indicates important information, that if not followed, may cause damage to equipment.**

## General Safety Information

### CALIFORNIA PROPOSITION 65

### ⚠ WARNING

**This product or its power cord may contain chemicals known to the State of California to cause cancer and birth defects or other reproductive harm. Wash hands after handling.**

1. Know the pump application, limitations, and potential hazards. Read these rules and the instructions carefully. Failure to follow them could cause serious bodily injury and/or property damage.

### ⚠ DANGER

**Never run engine in an enclosed area. Exhaust gases contain deadly poisonous carbon monoxide, which has no odor or taste.**



### ⚠ WARNING

**Do not use to pump flammable or explosive fluids such as gasoline, fuel oil, kerosene, etc. Do not use in flammable and/or explosive atmospheres. Pump should only be used with liquids compatible with pump component materials. Failure to follow this warning can result in personal injury and/or property damage.**



2. Observe all safety precautions for the handling of the fuel.

### ⚠ WARNING

**Do not refuel a hot engine. Fuel spilled on a hot engine could result in a fire or explosion. Do not refuel a running engine.**



3. Pump should be located and should rest on a level solid foundation. Do not suspend pump by means of the discharge pipe.

### NOTICE

**Be sure pump is on secure footing so it doesn't fall over.**

4. Do not use torches or apply excessive heat, fire or flames to this pump as an explosion may result.

5. Before working on the unit, insulate the wire from the spark plug, by disconnecting the spark plug wire from the spark plug.

### NOTICE

**Complete pump and piping system MUST be protected against below freezing temperature. Failure to do so could cause serious damage and voids the warranty.**

6. Do not run pump dry. Water is required to lubricate the shaft seal.
7. Pumping chemicals or corrosive liquids with this pump may shorten the life of the pump and may be hazardous to the operator.
8. Personal Safety:
  - a. Wear safety glasses at all times when working with pumps.
  - b. Keep work area clean, uncluttered and properly lighted; replace all unused tools and equipment.
  - c. Keep visitors at a safe distance from the work area.
  - d. Make workshop child-proof with padlocks, master switches, and by removing starter keys.
9. This pump is designed for non-abrasive fluid transfer; do not use as a trash pump. Always use a suction strainer with this pump to filter abrasive material. Abrasive materials such as sand and gravel will shorten the life of the pump.

**REMINDER: Keep your dated proof of purchase for warranty purposes! Attach it to this manual or file it for safekeeping.**

## Installation

This pump is designed to be self-priming when installed and operated as specified below.

1. The pump should be placed as close as possible to the water being pumped. A pump with 20 foot suction lift will not remove water as quickly as a pump with 5 foot suction lift (Figure 1).

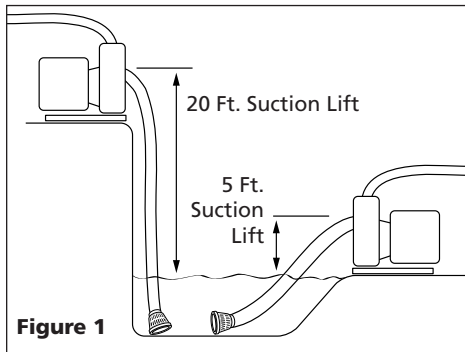

2. Suction hose and fitting must be airtight.

**NOTICE** *An air leak in the suction line may prevent priming of the pump. Use of thread sealant is recommended.*

Suction lines must be reinforced hose or rigid pipe. Non-reinforced hose will collapse due to the suction created by the pump and prevent pump from operating.

3. A check valve must be used in the suction line to maintain the self-priming capability. If no check valve is used the pump will need to be primed at the start of each operation. For best operation, the check valve should be installed at the intake of the suction line. (Figure 2).

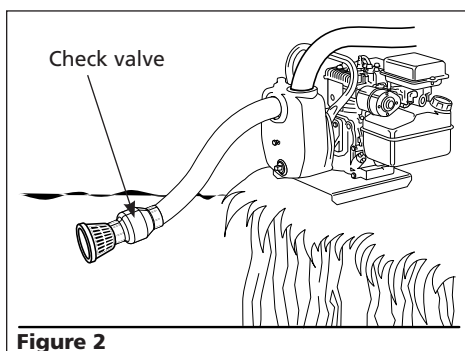

4. A suction strainer is required to filter abrasive material. Abrasive material, such as gravel, will destroy the pump and void the warranty. This pump is not designed to handle abrasive materials.
5. The discharge hose and fitting should be leak-tight. A leak in the discharge hose will allow water to spray around the work site, making the site hazardous.
6. Keep all pipes and hose lines as short and straight as possible. Long lengths and curves in the pipes and hose lines will reduce the pressure the pump develops.
7. Fill the engine crankcase with oil. Refer to the engine operating manual for the specific grade of oil and amount required.
8. Fill the engine fuel tank with gasoline. Refer to the engine operating manual for specific gasoline type that is most efficient for this engine.
9. Add water to the priming port on the pump (See Figure 3). Continue adding water until the water level is approximately 3 inches from the top. Install the priming plug. The water in the pump will create the suction that primes the pump.

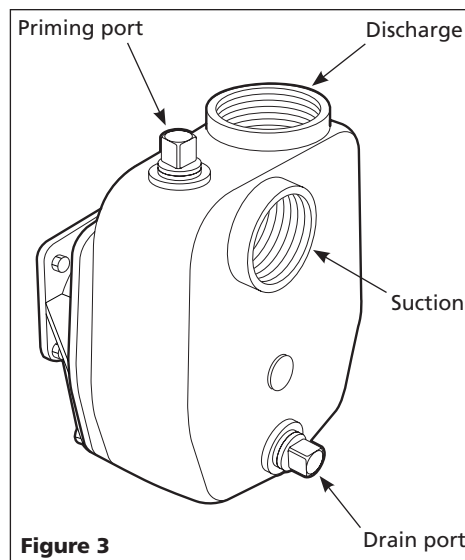

10. Turn fuel valve to 'ON' position
11. Move choke level to 'CHOKE' position.

12. Move the engine switch to 'ON' position.
13. Pull engine crank until engine starts. Once engine starts, move choke lever to 'RUN' position.
14. The pump will take several minutes to prime.

### PIPING

Always place the pump as close as possible to the water being pumped. Keep all pipe and hose lines as short and straight as possible.

**WARNING** *Support pump and piping when assembling and after installation. Failure to do so may cause piping to break, pump to fail, etc; all of which can result in property damage and/or personal injury.*

All suction connections must be airtight. If the pump won't prime, check for leaks in the suction piping or fittings. If flexible suction hose is used instead of pipe, use reinforced hose with a two inch inner diameter. Non-reinforced flexible hose may collapse from the vacuum created as the pump primes.

Always use a strainer at the end of the suction pipe or hose. Position strainer so it doesn't become clogged with stones or debris. A suction line check valve is recommended.

Do not use this pump for suction lifts over twenty-five feet.

## Maintenance

Always shut off the engine, allow the engine to cool, and remove the spark plug before performing any maintenance.

During freezing weather, open the drain port and allow all the water in the pump to drain. This will prevent damage to the pump when the water freezes. If the pump will be stored for a month or more, drain the water from the pump and follow the engine manufacturer's recommendations for long-term storage.

## Performance Information

### 2" Cast Iron Pump Performance

CAPACITIES IN GALLONS PER HOUR						
Discharge Head - Feet	Dynamic Suction Lift - Feet					
	0	5	10	15	20	25
20	6600	6420	6180	6000	5640	5220
30	6180	6000	5640	5220	4800	4380
40	5640	5220	4800	4380	4080	3660
50	4800	4380	4080	3660	3300	2820
60	4080	3660	3300	2820	2400	1800
70	3300	2820	2400	1800	1260	720
80	2400	1800	1260	720	0	0

FEET FRICTION LOSS IN 100 FEET OF PLASTIC PIPE									
Pipe Size	Gallons Per Minute								
	20	25	30	40	50	60	80	100	120
1 1/4	5.6	8.5	11.9	20.2	30.5				
1 1/2	2.6	4.0	5.5	9.4	14.3	19.9	34.2		
2		1.2	1.6	2.8	4.2	5.8	9.9	15.0	21.2
2 1/2				1.2	1.8	2.5	4.2	6.3	8.8

### PERFORMANCE CURVE

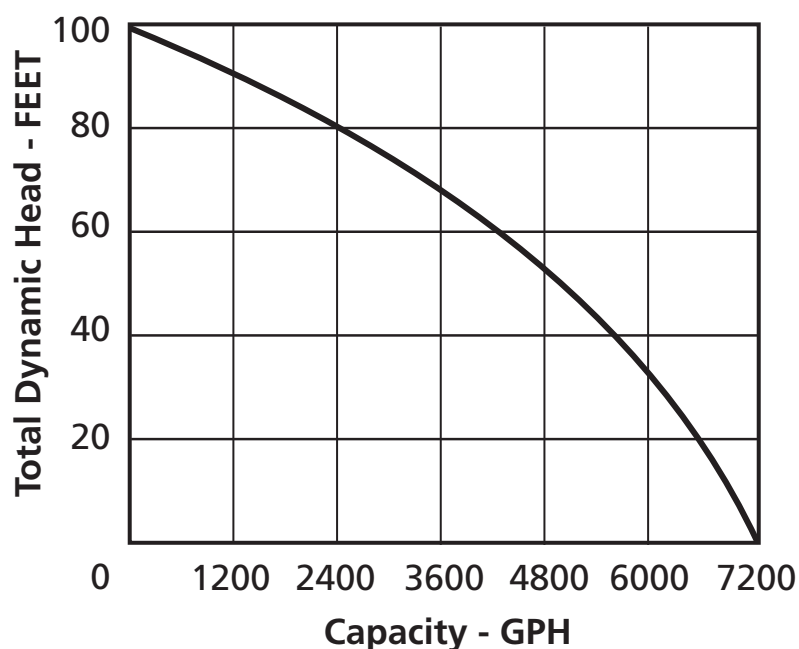

## **For Pump Accessories, call 1-800-237-0987**

*Please provide following information:*

- Model number
- Serial number (if any)
- Part description and number as shown

*Address parts correspondence to:*

Wayne Water Systems  
101 Production Drive  
Harrison, OH 45030

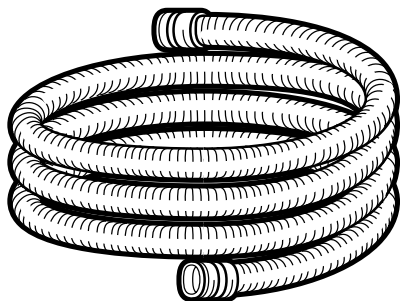

### **SUCTION HOSE**

#### **PART #16510-002**

- Reinforced to prevent collapse under suction

Hose coupled both ends with 2" hose thread. One 20 ft. hose per carton

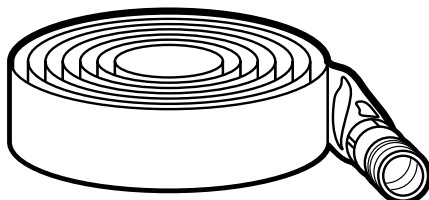

### **LAY FLAT DISCHARGE HOSE**

#### **PART #16511**

- Economical
- Lightweight
- Resistant to oils, light chemicals, abrasion and sunlight
- Will not rot, mildew or absorb water

Hose couples one end with 2" hose thread. One 25 ft. hose per carton



### **2" SUCTION STRAINER**

#### **PART #66036**

- Prevents stones, leaves and other debris from clogging pump

## For Replacement Parts, call 1-800-237-0987

Please provide following information:

- Model number
- Serial number (if any)
- Part description and number as shown

Address parts correspondence to:

Wayne Water Systems  
101 Production Drive  
Harrison, OH 45030

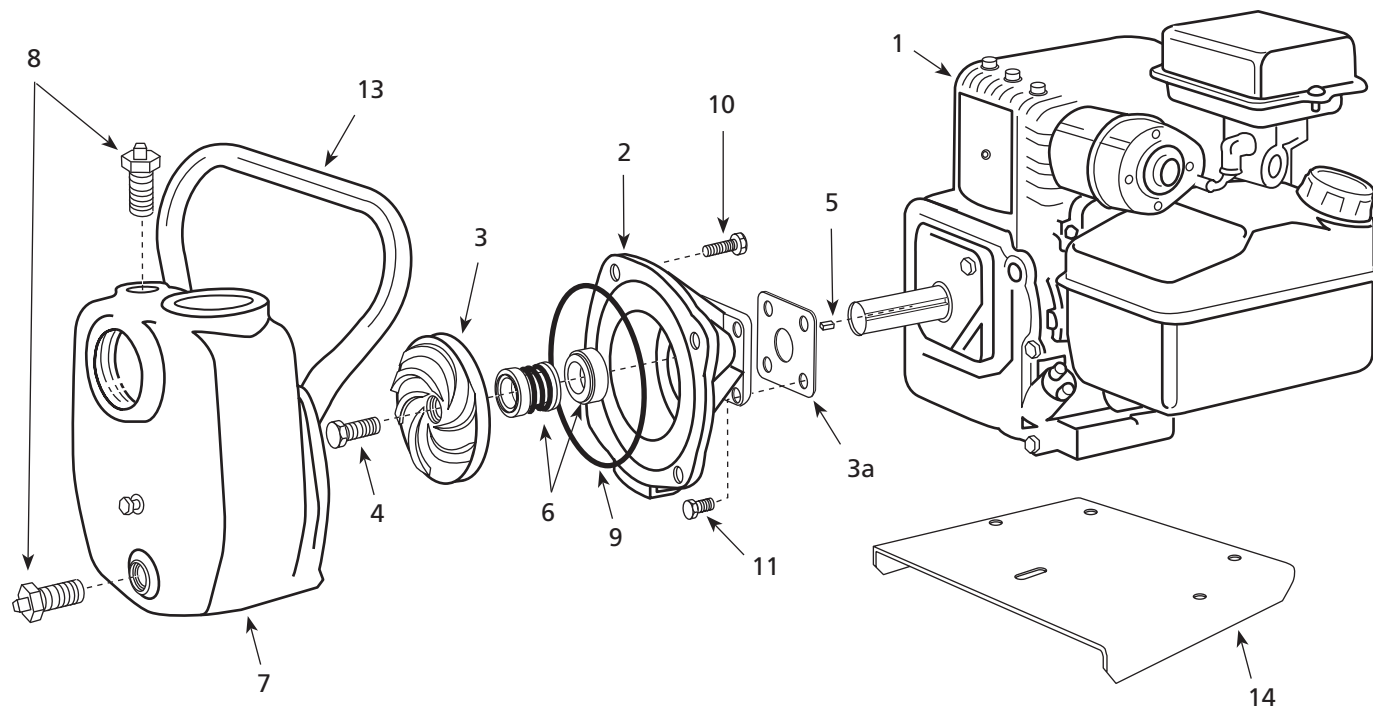

Item No.	Description	Part Number	Qty
1	Engine	57824-001	1
2	Volute Bracket	56724-001	1
3 & 3a	Impeller kit with shims	66057-WYN1	1
4	Screw	17046-001	1
5	Key	16997-001	1
6	Shaft seal kit (VITON®)	56712	1
7	Volute	56723-001	1
8	Pipe plug, 3/4 NPT	15921	2
9	Volute gasket	15556-002	1
10	Capscrew, 5/16 - 18 x 1	12701	5
11	Capscrew, 5/16 - 24 x 7/8	16209	4
12	Lockwasher, split 5/16 (not shown)	15916	4
13	Handle	56722-001	1
14	Base	11007-001	1





### Limited Warranty

For one year from date of purchase, Wayne Water Systems ("Wayne Water Systems") will repair or replace, at its option, for the original purchaser any part or parts of its Sump Pumps or Water Pumps ("Product") found upon examination by Wayne Water Systems to be defective in materials or workmanship. Please call Wayne Water Systems (800-237-0987) for instructions or see your dealer. Be prepared to provide the model number when exercising this warranty. All transportation charges on Products or parts submitted for repair or replacement must be paid by purchaser.

This Limited Warranty does not cover Products which have been damaged as a result of accident, abuse, misuse, neglect, improper installation, improper maintenance, or failure to operate in accordance with Wayne Water Systems's written instructions.

**THERE IS NO OTHER EXPRESS WARRANTY. IMPLIED WARRANTIES, INCLUDING THOSE OF MERCHANTABILITY AND FITNESS FOR A PARTICULAR PURPOSE, ARE LIMITED TO ONE YEAR FROM THE DATE OF PURCHASE. THIS IS THE EXCLUSIVE REMEDY AND ANY LIABILITY FOR ANY AND ALL INDIRECT OR CONSEQUENTIAL DAMAGES OR EXPENSES WHATSOEVER IS EXCLUDED.**

Some states do not allow limitations on how long an implied warranty lasts, or do not allow the exclusions or limitations of incidental or consequential damages, so the above limitations might not apply to you. This limited warranty gives you specific legal rights, and you may also have other legal rights which vary from state to state.

In no event, whether as a result of breach of contract warranty, tort (including negligence) or otherwise, shall Wayne Water Systems or its suppliers be liable for any special, consequential, incidental or penal damages including, but not limited to loss of profit or revenues, loss of use of the products or any associated equipment, damage to associated equipment, cost of capital, cost of substitute products, facilities, services or replacement power, downtime costs, or claims of buyer's customers for such damages.

You **MUST** retain your purchase receipt along with this form. In the event you need to exercise a warranty claim, you **MUST** send a **COPY** of the purchase receipt along with the material or correspondence. Please call Wayne Water Systems (800-237-0987) for return authorization and instructions.

**DO NOT MAIL THIS FORM TO WAYNE WATER SYSTEMS.** Use this form only to maintain your records.

MODEL NO. \_\_\_\_\_ SERIAL NO. \_\_\_\_\_ INSTALLATION DATE \_\_\_\_\_

**ATTACH YOUR RECEIPT HERE**