



# ENGINE PUMP

High Performance Self-Priming Engine Pump

## OPERATION MANUAL

Common points for all series

- Thank you for choosing a Powermate® Engine Pump.
- This manual is prepared for your safety when operating pump. Please read carefully and comprehend fully before use. (Wrong usage could cause injury or death.)
- Please keep this manual handy for future reference.

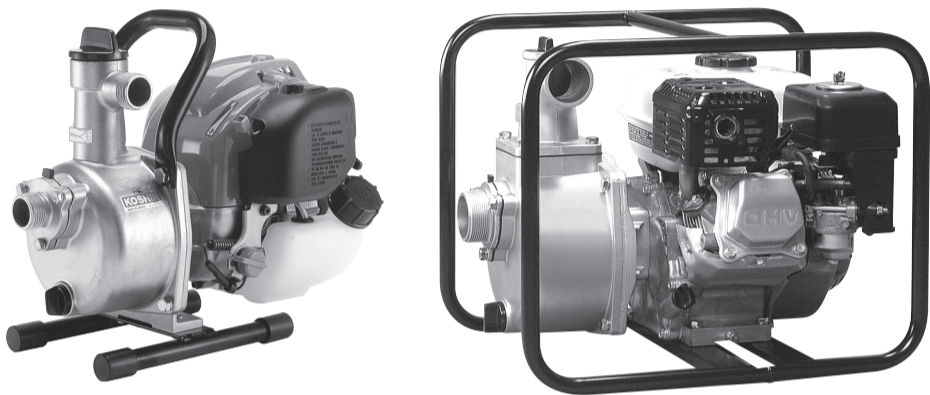

**Pramac America, LLC**  
**P.O. Box 6001 Kearney, NE 68848**  
**1-800-445-1805**

11-12 0070092

### CAUTION

#### 1. Application

As this pump is designed for agricultural use, do not use with muddy water

- \* Trouble if you don't observe. Could damage mechanical seal.

#### 2. Priming

As this pump is self-priming type, fill water fully into priming port before running.

- \* Trouble if you don't observe. Impossible to start pumping and may damage mechanical seal.

#### 3. Connection of suction hose

If pump does not work after filling water into priming port, it is likely due to poor connection of suction hose. In such case, check hose connection again before starting pump.

- \* Trouble if you don't observe. Impossible to pump.

#### 4. Engine oil

Fill engine oil into oiling port, shown in illustration, at the bottom of engine.

Change oil every 8 hours for the first 20 hours and every 50 hours thereafter.

Applied oil : SAE#30 (spring-summer),  
 SAE#20 (autumn-winter),  
 SAE10W-30 (cold district, below-10°C)

- \* Trouble if you don't observe. Engine failure will occur.

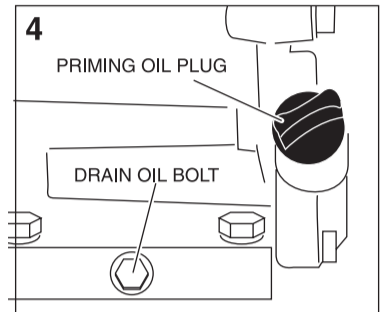
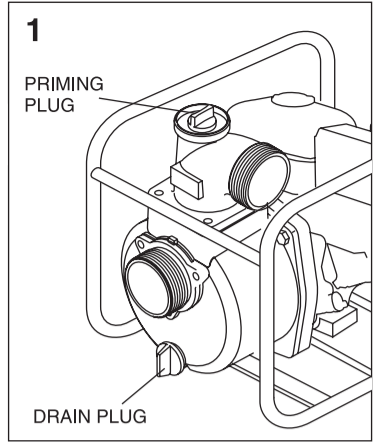

#### 5. Drain water after use

Water inside may freeze at below 0°C in winter and may damage pump.

After use, drain water from drain plug before storing.

- \* Trouble if you don't observe. Breakage of pump casing.

#### 6. Long storage

Discharge fuel from fuel tank and carburetor completely.

- \* Trouble if you don't observe. Impossible to start engine in future. (Engine details, refer Engine Operation Manual.)

#### 7. Prevent water hammer

Do not abruptly compress discharge hose during operation.

- \* Trouble if you don't observe. Breakage of pump casing.

### SAFETY PRECAUTIONS

Read this "Safety Precautions" before operation.

Below information should not be neglected for proper use of this product. Your understanding can prevent harm or danger to user or others.

Following information is very important for safety in handling this product. Be sure to observe them.

	<b>DANGER</b>	Indicates an imminently hazardous situation which, if not avoided, will result in death or serious injury.
	<b>WARNING</b>	Indicates a potentially hazardous situation which, if not avoided, could result in death or serious injury.
	<b>CAUTION</b>	Indicates a potentially hazardous situation which, if not avoided, may result in minor or moderate injury, or property damage.
<b>IMPORTANT</b>	<b>PROHIBITED</b> <b>ALERT</b>	

### DANGER

	<b>Avoid fire when refuel or maintenance.</b> Highly flammable!
	<b>Do not operate pump inside a room or under bad ventilation condition.</b> Harmful substances are in exhaust gas. There is a danger of gas poisoning
	In case of operating pump in a well or in a hollow, the person operating the pump must <b>not enter the small space</b> as there is danger of gas poisoning
	<b>Do not use pump on slope.</b> Fuel spillage at tank cap or carburetor may cause fire.
	<b>Do not put any obstacle around engine muffler.</b> It may cause fire or breakage.
	<b>Read carefully and understand fully before use.</b>
	<b>Keep children away from pump when in operation.</b>
	<b>Do not overhaul or repair, except by person who is trained to do so.</b>

### CAUTION

	<b>Do not touch muffler or any part of the engine.</b> It could cause burn.
	<b>Use this pump for clean water or agriculture water.</b> Not Suitable: drinking water, mud water, seawater, kerosene, light oil, heavy oil, gasoline, chemical, acid, alkaline etc.
	<b>Use correct type of suction hose.</b> <b>Water temperature tolerance: 5 to 45°C.</b> May cause breakage if use outside the mentioned range.
	<b>Please don't run pump without water inside the pump.</b> This will cause pump damage.
	<b>Please use suction hose for suction side.</b> Please purchase suitable hose to fit to connection dia and suitable length.
	<b>Please firmly connect hose with coupling and hose band</b> when you connect suction or delivery hose to pump.
<b>LABEL</b>	Replace name plate if damaged/peeled, please order from service center.

### BEFORE USE

#### 1 Check accessories provided

List of accessories provided are printed on the pump manual.

#### 2 Fuel / Engine oil 4-stroke engine 4-stroke engine needs "engine oil"

There is **no engine oil in the engine**. Before starting engine, engine oil must be filled. If you start engine without engine oil, engine will burn out and it is difficult to repair.

(Warranty does not cover such claim.)

Please use **"Non-Lead Gasoline for Automobile"**.

	<b>WARNING</b> Inflammable!! Avoid fire when refuel or maintenance.
	Before starting engine, please check if engine oil is filled to required level. Without engine oil or shortage of engine oil can cause troubles for engine.
	Please read carefully Engine Operation Manual for engine oil instructions.
	Inflammable! Do not operate near open fire.
	Any fuel spillage must be cleaned completely.
	Check engine oil before operation. Check and refuel periodically. Please read Engine Operation Manual for instructions.
	Stop engine operation when refuel engine oil. Engine oil can be very hot after operation.

### 3 How to install Coupling

**CAUTION** Different accessories are suitable for different models. Please check connection diameter and install correct parts.

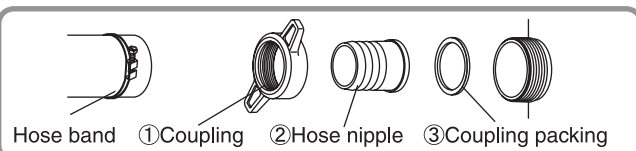

Please install coupling in order of :  
①⇒②⇒③  
If you install coupling packing not in above order, air leakage may result, affecting water suction efficiency.  
Do not change pump diameter by altering suction hose.

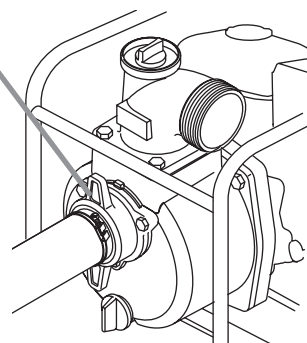

### 4 Make sure suction hose is connected properly

In case of no self-priming after filling pump with water and engine is started, check suction hose connection carefully again. Most cases of no self-priming are caused by improper hose connection.

**CAUTION** Use suction hose for suction side. Use couplings/hose band as provided in accessory and attach hose properly. Installation of strainer at the end of suction hose is necessary.

### 5 Fill pump with water before use

As pump is self-priming type, fill water fully from priming port into pump before running. Insufficient water can cause damage to pump.

**CAUTION** Running without filling water can damage mechanical seal.

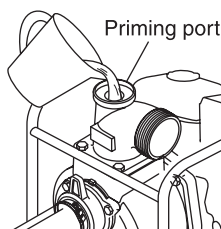

### HOW TO USE

- 1 Ensure pump is fully filled up with water.
- 2 Ensure strainer at the end of suction hose is in water. (If any mud or sand is at the bottom of water, suspend hose avoiding the bottom.)
- 3 Ensure no obstacle is at delivery hose side.

**CAUTION** **Beware of water hammering**  
Do not allow any vehicle to run over the delivery hose. Do not close the delivery valve abruptly because water-hammer may occur. This may result in heavy damage to the pump.  
For engine manual and notes, please refer Engine Operation Manual enclosed.

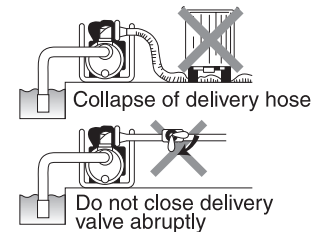

### ATTENTION AFTER USE

- 1 Drain water after use.

**CAUTION** Water inside may freeze at below 0°C in winter and may damage pump. After use, drain water from drain plug before storing.

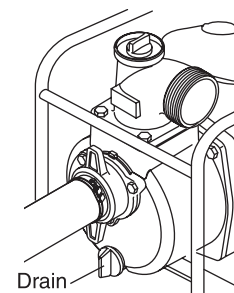

- 2 Long storage

Discharge fuel in fuel tank and carburetor completely. Unused fuel in tank (if kept more than 30days) may cause engine failure.  
\*Please refer Engine Operation Manual.

**CAUTION** Do not smoke as fuel is highly inflammable. Unused fuel must not remain in the tank for long term storage. Unused fuel may cause future engine failure.

### TROUBLESHOOTING GUIDE

PROBLEM	POSSIBLE CAUSE	SOLUTION
Cannot pull or hard to pull recoil starter	Old fuel	Replace to new fuel. If there is no improvement, repair engine.
	Rusting inside engine	Refer to Engine Operation Manual. (Repair)
	Burn out of engine	Refer to Engine Operation Manual. (Repair)
	Stick impeller	Dismantle & clean the impeller ⇒ SOLUTION ①
Not enough delivery volume	Obstacles at impeller	Dismantle & clean the impeller ⇒ SOLUTION ①
	Air leakage from suction side	Check piping at suction side ⇒ SOLUTION ②
	Output power down from engine	Check & Repair engine
	Damage of mechanical seal	Replace mechanical seal (Repair)
	Suction lift is high	Make suction lift lower
	Suction pipe is too long or smaller in diameter	Shorten suction pipe or enlarge diameter.
	Leakage of water from delivery hose or pipe	Check and stop leakage of water.
Pump does not prime water	Obstacles at impeller	Dismantle & clean the impeller ⇒ SOLUTION ①
	Wearing out of impeller	Replace the impeller (Repair)
	Air goes in from suction side	Check piping at suction side ⇒ SOLUTION ②
	Insufficient priming water inside pump casing	Pour more water into pump casing for priming. Refer [BEFORE USE] "5 Fill pump with water before use"
	Drain plug is not tighten	Tighten drain plug firmly. Please refer "ATTENTION AFTER USE"
Engine does not start.	Imperfect revolution of engine	Refer to Engine Operation Manual.
	Damage of mechanical seal (NOTE)	Replace mechanical seal (Repair)
	Wrong suction hose used	Use suction hose correctly
	Carburetor is choked	Repair
	Spark Plug is wet	Check & repair the plug ⇒ SOLUTION ③
	Air cleaner dirty	Clean air cleaner. (Refer to Engine Operation Manual.)
	Too much engine oil (4-cycle engine)	Adjust engine oil to suitable level.
	Insufficient engine oil (4-stroke engine)	Function of oil alert (oil sensor) is working. (This function protects engine. If volume of engine oil is not suitable level, engine does not start.)
	Even if you check above points, still engine does not start.	Possibility of damage, inner parts of engine (Repair)
	Oil leakage from muffler or air cleaner	Fall of engine. Repair

#### SOLUTION ①

Remove obstacle in impeller. (Please don't remove impeller)

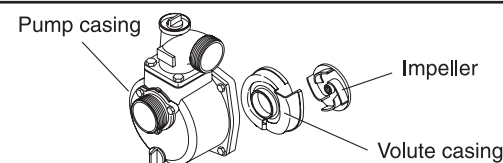

#### SOLUTION ②

##### Check suction pipe.

In case of no suction or small delivery, the cause is usually due to air leakage at suction side.

In such case :

- ① Remove suction hose
- ② Start engine with water inside the pump.
- ③ Press the palm of your hand to cover the suction hole and wait 30 seconds. If you feel suction on your palm, the pump is working fine but hose connection needs correction.
- ④ Please check if rubber packing is installed and if there is any hole on suction hose

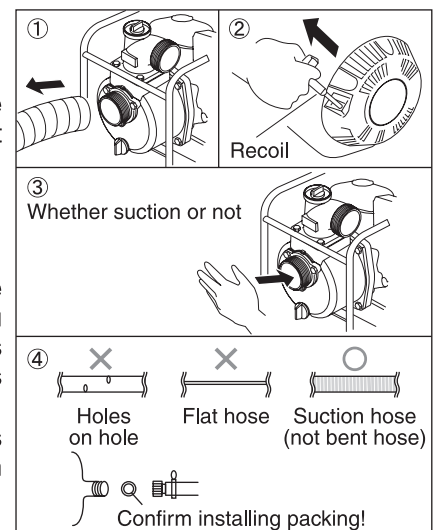

#### SOLUTION ③

##### Confirm spark plug if wet or stained.

Please clean plug with cloth if spark plug is wet or stained.



##### Confirm gap between spark plug.

Plug gap should be 0.6~0.7mm. Adjust gap to be within this range.



- New spark plug may be required, if engine cannot start even after you clean plug or adjust gap of plug.

**CAUTION** There are many different types of spark plugs. Please check and select correct plugs according to Engine Operation Manual.

#### NOTE

In case of water leakage between engine and pump, usually the cause is damaged mechanical seal. Please ask shop for assistance and replace mechanical seal.

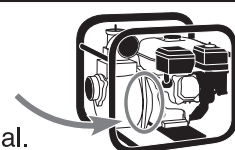

**CAUTION** For assistance and repair, please ask your nearest service center for after sales service.

## SPECIFICATIONS

Model		PP0100381	PP0100364	
PUMP	Connection Dia	25 mm (1")	50mm (2")	
	Connection Thread	Outer Pipe Thread	NPT Thread	
	Total Head	106 ft. (32.30m)	95 ft. (29m)	
	Delivery Volume	30 USG/min (115 L/min)	158 USG/min (600 L/min)	
	Max. Suction Head	26 ft (8 m)		
ENGINE	Model	HONDA GX25	HONDA GX120	
		Forced Air-cooled 4-stroke Gasoline Engine		
	Exhaust Volume	25 cc	118 cc	
	Output	Rated Power	—	2.1 kW (2.9PS) / 3600 rpm
		Max. Power	0.72 kW (1.0 PS) / 7000 rpm	2.6 kW (3.5 PS) / 4000 rpm
	Fuel	Automotive Unleaded Gasoline		
	Fuel Tank Capacity	0.15 USG (0.58 L)	0.53 USG (2.0 L)	
	Starting Method	Recoil Starter		
Coutinuous Operating Time	Approx.1hr (full tank)	Approx.2hrs (full tank)		
Standard Accessories	1 Strainer, 2 Hose Couplings, 3 Hose Bands (φ 32)	1 Engine Tool Set		
Net Weight	12.1 lbs (5.5 kg)	50.7 lbs (23 kg)		

\*For the purpose of improvement, specifications are subject to changes without notice.

## PERFORMANCE CURVE

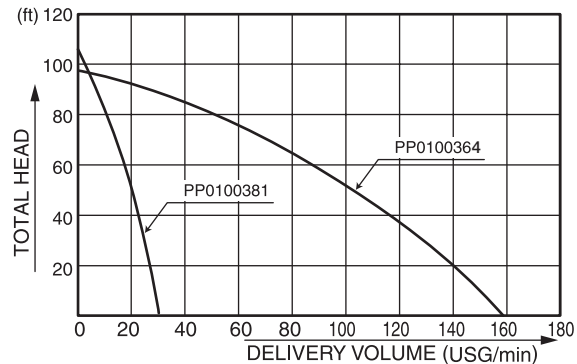

\*Performance ratings are guaranteed minimum, not inflated maximum.

## PARTS LIST

### PP0100381

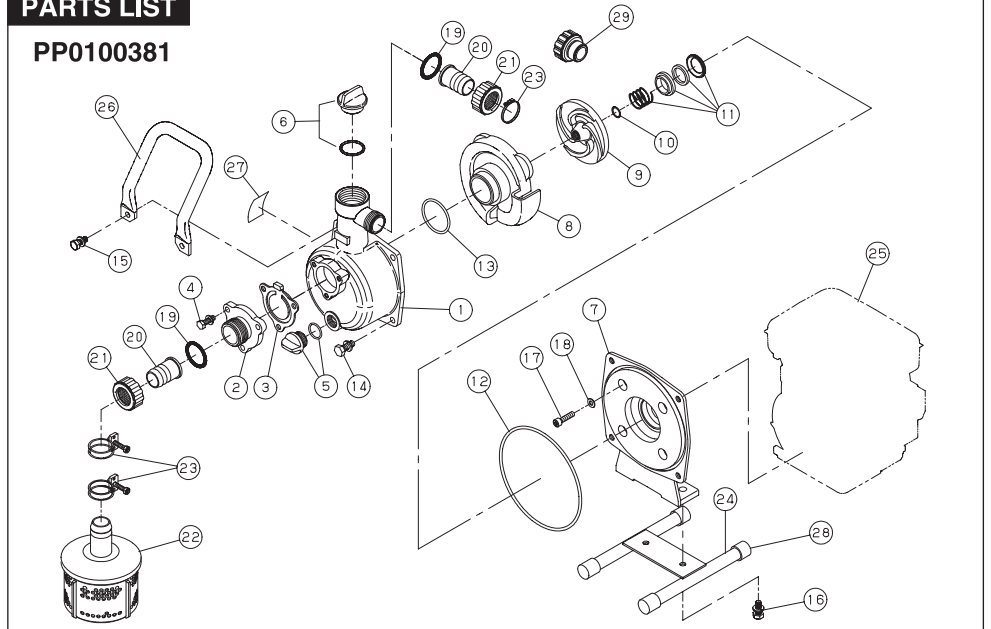

### PP0100381

REF. NO.	PART NO.	DESCRIPTION	QTY
1	PPK0115108	Pump Casing	1
2	PPK0113325	Suction Flange	1
3	PPK0113326	Check Valve	1
4	PPK743119032	Bolt HH M6 × 20	3
5	PPK0148010	15A Plug Set	1
6	PPK0118450	32A Plug Set	1
7	PPK0114992	Flange Bracket	1
8	PPK0112528	Volute Casing	1
9	PPK0114993	Impeller	1
10	PPK0113944	Adjusting Washer	3
11	PPK0116054	Mechanical Seal	1
12	PPK890255031	Oring 1517-31	1
13	PPK889855042	Oring P42	1
14	PPK743119045	Bolt HH M8 × 20	2
15	PPK743119046	Bolt HH M8 × 22	2
16	PPK743119043	Bolt HH M8 × 16	2
17	PPK734532274	Screw SHC M5 × 40	4
18	PPK854255005	Seal Washer	4
19	PPK0340065	Gasket	2
20	PPK0340782	Hose Nipple	2
21	PPK0340781	Coupling	2
22	PPK0118193	Strainer	1
23	PPK940019032	Hose Band	3
24	PPK0118267	Base Set	1
25	Note A	Engine Honda GX25	1

REF. NO.	PART NO.	DESCRIPTION	QTY
26	PPK0114277	Handle	1
27	0070095	Name Plate	1
28	PPK0112576	Pipe Rubber Cover	4
29	PPK0120424	Hose Adapter	1

Note A: Pramac America, LLC will not provide engines as replacement parts. Engines are covered through the engine manufacturer's warranty. Consult the accompanying engine manual or contact our service department for assistance.

## PARTS LIST

PP0100364

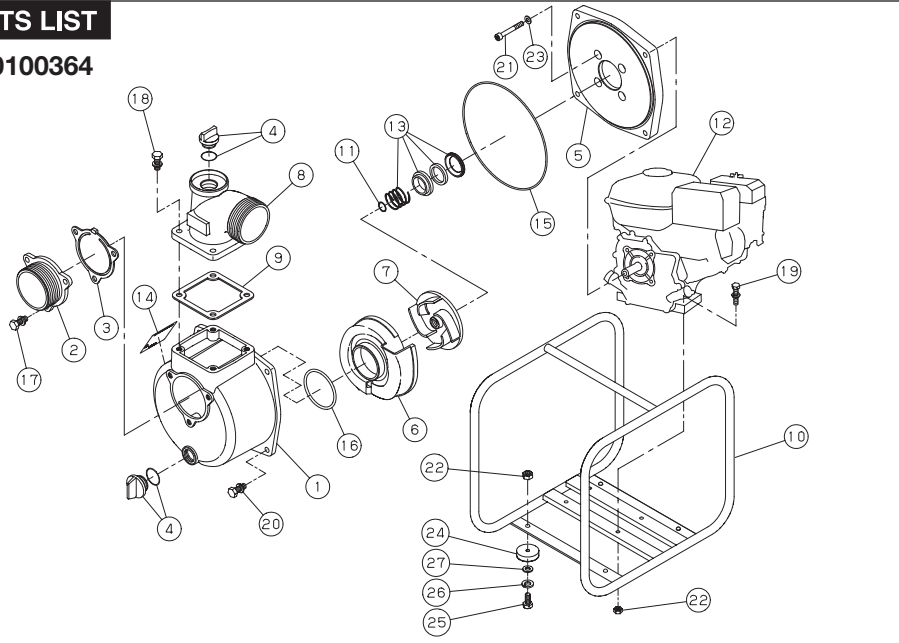

## PP0100364

REF. NO.	PART NO.	DESCRIPTION	QTY
1	PPK0112578	Pump Casing	1
2	PPK0112822	Suction Flange	1
3	PPK0112665	Check Valve	1
4	PPK0118078	Plug and O-Ring	2
5	PPK0114027	Flange Bracket	1
6	PPK0115169	Volute Casing	1
7	PPK0115168	Impeller	1
8	PPK0111359	Delivery Flange	1
9	PPK0110541	Flange Packing	1
10	PPK0117086	Base Set	1
11	PPK0110466	Adjusting Washer	3
12	Note A	Engine Honda GX120	1
13	PPK0115159	Mechanical Seal	1
14	0070105	Name Plate	1
15	PPK0115014	O-ring 1517-42.5	1
16	PPK0112792	O-ring P54	1
17	PPK743119045	Bolt M8 x 20	3
18	PPK743119047	Bolt M8 x 25	4
19	PPK743119051	Bolt M8 x 35	4
20	PPK743119046	Bolt M8 x 22	4
21	PPK734532076	Socket bolt M8 x 60	4
22	PPK827419008	Nut M8	8
23	PPK854255008	Seal Washer	4
24	PPK0110515	Cushion Rubber	4
25	PPK735719148	Bolt M8 x 20	4

REF. NO.	PART NO.	DESCRIPTION	QTY
26	PPK843822008	Spring Washer	4
27	PPK846007008	Washer	4

Note A: Pramac America, LLC will not provide engines as replacement parts. Engines are covered through the engine manufacturer's warranty. Consult the accompanying engine manual or contact our service department for assistance.

## CUSTOMER SERVICE

Call our toll free number 1-800-445-1805

7 a.m. to 5 p.m. C.S.T. or [www.powermate.com](http://www.powermate.com) to obtain warranty service information or order replacement parts or accessories. Please have the following information available:

1. Model Number.
2. Serial Number.
3. Date and where purchased.
4. Replacement numbers if you are ordering part

Pramac America, LLC P O Box 6001 Kearney, NE 68848

Attention: Warranty Service Department

[www.powermate.com](http://www.powermate.com)

## LIMITED WARRANTY

**Warranty Coverage:** Pramac America, LLC (the Company) warrants to the original retail customer in North America that it will repair or replace, free of charge, any parts found by the Company or its authorized service representative to be defective in material or workmanship. This warranty covers the cost of replacement parts and labor for defects in material or workmanship.

### Not Covered:

- Transportation charges for sending the product to the Company or its authorized service representative for warranty service, or for shipping repaired or replacement products back to the customer; these charges must be borne by the customer.
- Engine is covered exclusively by a separate warranty from the engine manufacturer, included with the engine Manual.
- Damages caused by abuse or accident, and the effects of corrosion, erosion and normal wear and tear.
- Warranty is voided if the customer fails to install, maintain and operate the product in accordance with the instructions and recommendations of the Company set forth in the owner's manual, or if the product is used as rental equipment.
- The Company will not pay for repairs or adjustments to the product, or for any costs or labor, performed without the Company's prior authorization.

**Warranty Period:** One (1) year from the date of purchase on products used for consumer, business or commercial applications.

For warranty service, the customer must provide dated proof of purchase and must notify the Company within the warranty period.

**For warranty service: Call toll free 800-445-1805, or write to Pramac America, LLC, Product Services, P. O. Box 6001, Kearney, NE 68848.**

**Exclusions And Limitations:** The company makes no other warranty of any kind, express or implied. Implied warranties, including warranties of merchantability and of fitness for a particular purpose, are hereby disclaimed. The warranty service described above is the exclusive remedy under this warranty; Liability for incidental and consequential damages is excluded to the extent permitted by law.

This warranty gives you specific legal rights, and you may also have other rights which vary from state to state. Some states do not allow a disclaimer of implied warranties, or the exclusion or limitation of incidental and consequential damages, so the above disclaimers and exclusions may not apply to you.